

Article 18 – Signs

25.18.01 – Legislative Findings; Purposes

- a. *Legislative Findings* – The Mayor and Council finds that signs provide an important medium through which individuals and entities may convey a variety of commercial and noncommercial messages. However, left completely unregulated, signs can become a threat to public safety as a hazard to property, persons, and the motoring public, and a detriment to property values and the overall public welfare as a nuisance.
- b. *Purposes* – In addition to the purposes of this Chapter established in Section 25.01.02, the purposes of this Article are:
 1. To enable the public to locate goods, services, facilities, and geographic areas without difficulty, danger, or confusion;
 2. To reduce traffic and pedestrian hazards and prevent interference with the effectiveness of traffic regulation;
 3. To promote the compatibility of signs with the surrounding land uses;
 4. To protect the public investment in the roadways in the City;
 5. To promote and preserve the economic well-being and vitality of the community;
 6. To enhance and improve the environment of the City and to protect property values by preventing visual clutter and blight;
 7. To preserve the residential character of the City’s residential neighborhoods; and
 8. To provide effective opportunities for the expression of commercial and noncommercial communication while protecting the public and the community against adverse affects from the unrestricted proliferation of signs.

25.18.02 – Severability

- a. Without diminishing or limiting in any way the declaration of severability in Section 25.01.08 it is the express intent of this Section that if any provision (including any section, sentence, clause, or phrase) of this Article 18 or any other provision of this Chapter pertaining to signs, including but not limited to provisions pertaining to sign permits, is declared by a court of competent jurisdiction to be unconstitutional and void, such declaration of unconstitutionality does not affect any other provision of this Article 18 or other provision of this Chapter, including, but not limited to, the prohibition of certain signs, and the requirements pertaining to the size, height, location, numbers, illumination, maintenance, construction, and removal of signs.
- b. In particular, and without limitation, in the event any provision of this Article 18 or other provision of this Chapter is declared invalid as applied to noncommercial signs, this Article 18 or any surviving portions thereof, remain in full force and effect as applied to commercial signs.

- c. Without diminishing or limiting in any way the foregoing declaration of severability, it is the express intent of this Section, 25.18.02, that if any provision (including any section, sentence, clause, or phrase) of this Article 18 or any other provision of this Chapter pertaining to signs is declared by a court of competent jurisdiction to be unconstitutional and void, such declaration of unconstitutionality does not affect any other provision of this Article 18 or other provision of this Chapter even if such severability would result in a situation where there would be less speech, whether by subjecting previously exempt signs to the provision of this Chapter or otherwise.

25.18.03 - Special Application Requirements for the Sign Review Board

In addition to the general provisions pertaining to the Sign Review Board found in 25.04.05 and general provisions for applications in Article 5, applications authorized in this Article 18 must:

1. Be submitted in writing to the Sign Review Board at least ten (10) calendar days prior to the meeting at which it is to be considered;
2. Be submitted on forms provided by the Sign Review Board and be accompanied by such fee as is determined by resolution of the Mayor and Council; and
3. Include as part of the application such information as may reasonably be required by the Sign Review Board including:
 - (a) The street address of the property upon which the sign is to be located and a plat map of the property showing the proposed location of the sign and identifying any adjacent residential property;
 - (b) The aggregate area for all tenant / business signs erected by or on behalf of the applicant and/or the aggregate area for all signs on the premises;
 - (c) The name(s) and address(es) of the owner(s) of the premises upon which the subject sign is to be located;
 - (d) Consent of the owner(s), or the owner's agent, granting permission for the placement or maintenance of the sign;
 - (e) The name, address, phone number, and business license number of the sign contractor;
 - (f) Plans indicating the location of the sign on the property or building wall, including the road frontage and/or building elevation; and
 - (g) Plans indicating the dimensions, height, and shape of the sign, and materials, and mounting details.
4. *Expiration of Sign Review Board's Approval.*
 - (a) *Installation of Sign* - A sign must be installed within six (6) months of the Sign Review Board's decision authorizing such sign, unless another time frame is provided within this Chapter or the decision of the Sign Review Board, or the approval shall expire.

- (b) *Extension* - The Sign Review Board may, for good cause shown, grant no more than two (2) extensions of not more than six (6) months each for any prior grant of approval subject to the provisions for an extension of Section 25.05.08, "Extension of Implementation Period".

25.18.04 – Only Permitted Signs Lawful; Signs Specifically Prohibited

- a. No sign shall be erected, installed, substantially altered, or illuminated unless in compliance with all of the requirements of this Chapter.
- b. The following signs are specifically prohibited in the City:
 - 1. Signs that impede the operation of any window, door, fire escape, stairway, ladder, or opening required to provide light, air, ingress, or egress for any building or structure;
 - 2. Signs which, by reason of position, size, shape, or color, may interfere with, obstruct the view of, or be confused with any traffic sign, signal, or device, or which make use of any word, phrase, symbol, or character in such a manner as to interfere with, mislead, or confuse traffic;
 - 3. Off-premises signs;
 - 4. Freestanding signs in the shape or form of any person, animal, vegetable, product, or animation of any of the foregoing;
 - 5. Any sign placed or erected on property without the permission of the property owner;
 - 6. Signs which move or have any moving part, or which give the illusion of motion;
 - 7. Signs which use blinking, flashing, or fluttering illumination or illumination which varies in color or intensity or which create the appearance or illusion of writing or printing, including, but not limited to, strobe, rotating beacon, chasing, or zip lights;
 - 8. Signs erected by any person on any public property or right-of-way except for signs as may be directed by the City Manager;
 - 9. Signs erected in such a location as to interfere with pedestrian or vehicular circulation onto or off of the property on which it is located;
 - 10. Portable signs, except as may be allowed in Section 25.18.14.b.1.a.(v);
 - 11. Signs mounted, attached, or painted on trailers, boats, or motor vehicles when used as additional identification or advertising signs on or near the premises;
 - 12. Signs with changeable copy, except as provided for herein;
 - 13. Signs extending above the roof of any building in excess of one (1) percent of the building height;

- 14 Flags, banners, pennants, spinners, ribbon, streamers, balloons, and similar devices, except as expressly permitted by this Article;
- 15 Signs projecting more than 36 inches from a building wall; and
- 16 Any sign with words, scenes, or graphics of an obscene, indecent, or prurient character which offend public morals or decency.

25.18.05 – Exemptions

This Article does not apply to:

1. Any sign erected inside of any building and not visible from the exterior thereof;
2. Any sign erected inside of any building and visible outside of such building through a window, provided such sign is set back at least ten (10) feet from the nearest window;
3. Signs inside a building within ten (10) feet of any window not exceeding 20 percent of the area of a window unit;
4. Traffic control signs and speed indicator signs;
5. Any sign erected by or at the direction of, any governmental body having jurisdiction over the property or the right-of-way on which the sign is located;
6. Any sign or portion thereof required to be posted or displayed by this Chapter or other applicable Federal, State, or local law or regulation;
7. One (1) private flag when displayed with the flag of the United States and the State or political subdivision, provided such private flag must not be larger than the other flags displayed;
8. Signs located on public or private recreational facilities on parcels of five (5) acres or more, provided that such signs are not intended to be readable from a public way;
9. Any ornamental flag or stationary structure, device, material, or thing of a noncommercial decorative nature extending from a wall or pole located on residential property or around parking or pedestrian areas in the interior of non-residential property and not designed to attract the attention of those traveling on a public way; or
10. Numerals not exceeding 18 inches in height identifying the address of a dwelling unit or building.

25.18.06 – Construction, Design, Illumination, and Maintenance of Signs

- a. *Permanent Signs*

1. *Construction* – Permanent signs must be permanently attached to the ground, a building, or another structure by direct attachment to a rigid wall, frame, or structure.
 - (a) Signs attached to masonry, concrete, or steel must be safely and securely fastened by means of metal anchors, bolts, or approved expansion screws of sufficient size and anchorage to safely support the loads applied.
 - (b) Where wood anchors or supports are embedded in the soil, the wood must be pressure treated with an approved preservative.
 2. *Design* – Permanent signs must be designed and constructed to withstand wind pressure as provided for in the current edition of the International Building Code, as amended, or in such other code adopted as the Building Code for the City.
 3. *Illumination* – When illumination of a sign is permitted, it must satisfy the following requirements:
 - (a) A sign must not be illuminated by other than electrical means, and electrical devices and wiring must be installed in accordance with the requirements of the National Electrical Code, as amended, or such other code adopted as the Electrical Code for the City.
 - (b) Sign illumination must use an enclosed lamp design or indirect lighting from a shielded source in a manner that prevents glare from beyond the property line.
 - (c) Sign illumination must not cause traffic interference.
- b. *Temporary Signs*
1. *Construction* – Temporary signs must:
 - (a) Not be constructed in a manner that requires a building or electrical permit; and
 - (b) Be securely anchored to the structure or land in which it is located.
 2. *Design* – Temporary signs must not have changeable copy.
 3. *Illumination* – Temporary signs must not be illuminated in any manner.
- c. *Maintenance*
1. All signs and sign support structures, together with their supports, braces, guys, and anchors, must be maintained in good structural condition, in compliance with all applicable building and electrical codes, and in conformance with this Article at all times.
 2. The display surfaces of all signs must be kept neatly painted or posted at all times.

25.18.07 – Measurement of Sign Area and Height

a. *Sign Area*

1. Sign area includes the total areas of all permitted signs, except as otherwise provided for herein.
2. Sign areas are measured as follows:
 - (a) For sign copy mounted or painted on a background panel or area distinctively painted, textured, lighted, or constructed as background for the sign copy, sign area is measured as that area contained within the outside dimensions of the background panel or surface.

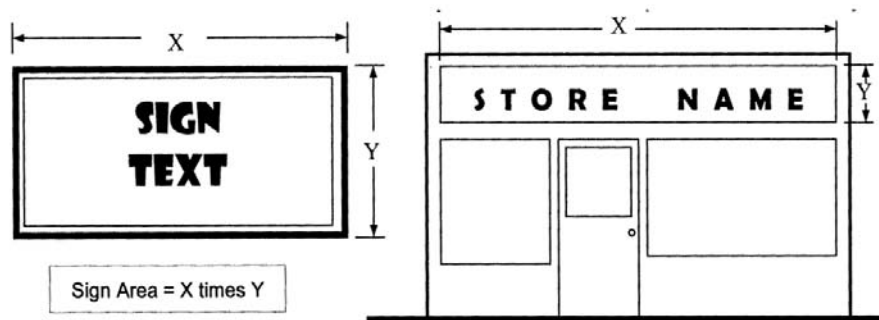

Figure 18.1

- (b) For sign copy mounted as individual letters and/or graphics on an area of a building that has not been painted, textured, lighted, or otherwise altered to provide a distinctive background for the sign copy, sign area is measured as the area or the sum of the areas enclosed by the smallest rectangle that will enclose each word and graphic.

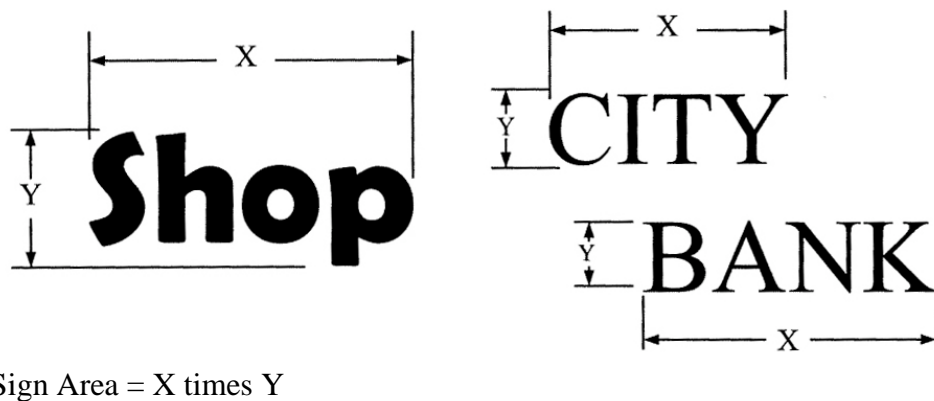

Figure 18.2

- (c) For freestanding signs or projecting signs not more than two (2) sign faces shall be allowed. If the interior angle between the two (2) sign faces is 90 degrees or less, the area of only one (1) face will be the sign area. If the angle between the two (2) faces is greater than 90 degrees, the sign area will be the sum of the areas of the two (2) faces.

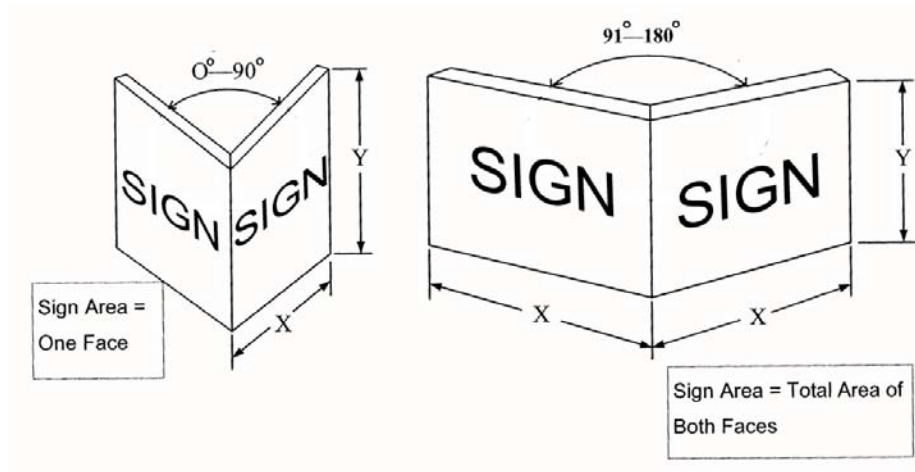

Figure 18.3

- (d) For a freestanding sign, the sign area will be the area that will encompass all components of the sign excluding the supporting structure that does not form part of the sign proper.

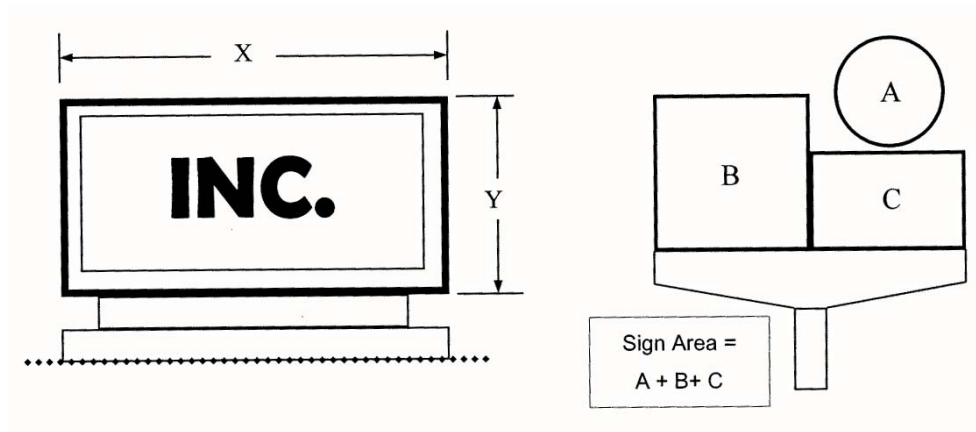
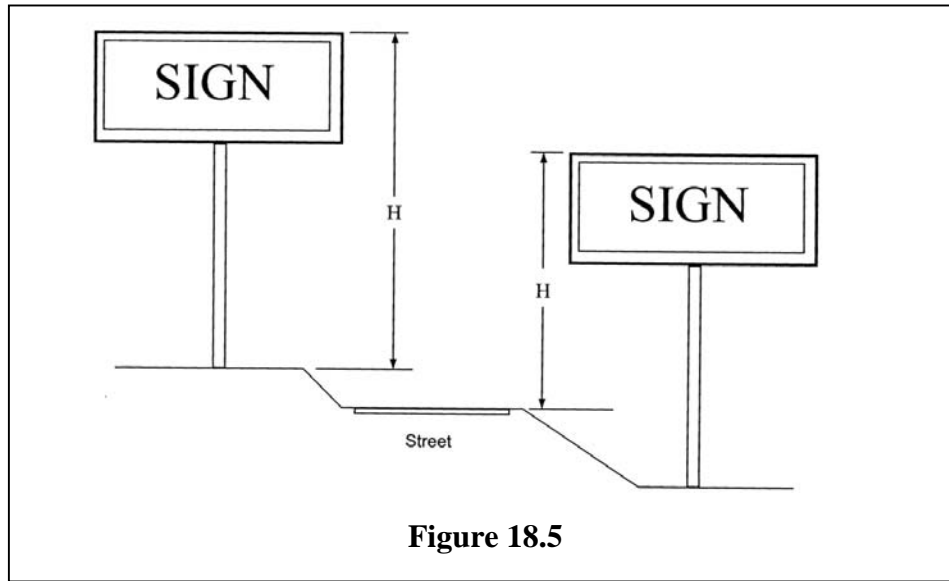

Figure 18.4

- b. *Sign Height* – Sign height is measured from the distance at the top of the sign structure to the level of the street upon which the sign faces or to the level of the lot on which the sign is erected, whichever is higher.



25.18.08 – Sign Permits; Appeals

- a. Except as expressly exempted or otherwise provided in this Article, a sign permit must be obtained prior to the installation, erection, enlargement, illumination, or substantial alteration of any permanent or temporary sign allowed under this Article. The changing of the sign face is a substantial alteration requiring a new sign permit.
- b. Applications shall be submitted to the Chief Planning.
- c. Each application shall be submitted on forms provided therefore by the Chief of Planning, and be accompanied by such fee as is established by resolution of the Council. The applicant shall furnish as part of the application the following information:
 1. The street address of the property upon which the sign is to be located and a plat map of the property showing the proposed location of the sign and identifying any adjacent residential property;
 2. The aggregate area for all tenant/business signs erected by or on behalf of the applicant and/or the aggregate area for all signs on the premises;
 3. The name(s) and address(es) of the owner(s) of the premises upon which the subject sign is to be located;
 4. Consent of the owner(s), or the owner's agent, granting permission for the placement or maintenance of the sign;
 5. The name, address, phone number, and business license number of the sign contractor;

6. Plans indicating the location of the sign on the property or building wall, including the road frontage or building elevation;
 7. Plans indicating the dimensions, height, and shape of the sign, and materials, and mounting details;
 8. The size and type of any vegetation required to be moved for sign installation or visibility; and
 9. Such other information pertaining to the requirements of this Article as may reasonably be required by the Chief of Planning.
- d. The Chief of Planning must review the application within 15 business days from the date of submission of the application and required fee and either approve or deny the application or return the application to the applicant if the application is incomplete as follows:
1. A sign permit must be issued if the Chief of Planning finds that the sign proposed in the application complies with the requirements of this Article.
 2. If the permit is denied, the denial must be in writing and must specify the specific section or sections of this Article or other applicable law with which the proposed sign(s) is inconsistent.
 3. If the application is returned due to incompleteness, the Chief of Planning must advise the applicant in writing as to the information needed to complete the application.
 4. Failure of the Chief of Planning to take action on an application within the time frame set forth above is appealable to the Sign Review Board in the same manner as an appeal from a denial of a permit.
- e. An applicant may appeal the denial of a sign permit by filing a sign permit review application with the Sign Review Board within ten (10) business days of the decision of the Chief of Planning.
- f. No permit for a sign issued hereunder shall be deemed to constitute permission or authorization to erect or maintain an unlawful sign, nor shall any permit issued hereunder constitute a defense in any action to remove an unlawful sign.

25.18.09 – Nonconforming Signs

- a. Whenever an existing sign is altered, it must be modified to bring it into conformance with this Chapter.
- b. Whenever an existing business / tenant erects a new or additional sign, all signs on the premises pertaining to that business / tenant must be modified to bring them into conformance with this Chapter.
- c. Any sign lawfully existing immediately prior to the effective date of this Chapter, or any application amendment thereof, but which does not conform to the requirements as

now constituted or as it may hereafter be amended from time to time, must be removed within eight (8) years from the date that the sign became nonconforming.

- d. In all other respects, nonconforming signs must comply with the applicable requirements of Article 8, Transitional Provisions, Nonconformities, Nonconforming Alteration Approval.

25.18.10 – Removal of Signs

- a. *Prohibited Signs on Public Property / Rights of Way* – Any prohibited sign found on any public property or right-of-way within the City will be removed and disposed of by the Chief of Inspection Services or designee in the same manner as trash. Nothing herein prohibits the imposition of a fine or initiation of any other enforcement action against any person or entity found to have installed a prohibited sign on any public property or right-of-way within the City.
- b. *Unlawful Sign* – Any sign unlawfully existing immediately prior to the effective date of this Chapter, or any applicable amendment thereof, and which does not conform to the requirements of this Article, as now constituted or as it may be amended from time to time, must be removed by the owner after notice from the City to do so.
- c. *Elections and Other Event Signs* – Any sign that pertains to an election, event, activity, or purpose of a limited time or duration must be removed within seven (7) days of the conclusion of the event, activity, or purpose to which it pertains. Nothing herein prohibits the maintenance of signs with a political or other noncommercial message in accordance with the provisions of the Article 18 pertaining to temporary noncommercial signs.
- d. *Abandoned Signs*
 - 1. An abandoned sign must be removed within 30 days from the time the activity on the premises ceases and/or the business owner vacates the premises by:
 - (a) The sign’s owner;
 - (b) The owner of the property on which the sign is located; or
 - (c) Any other persons otherwise responsible for the sign.
 - 2. Removal consists of the removal of the portion of the conforming sign identifying the business, tenant, entity, service, owner, product, or activity that is no longer located on the premises and installation of temporary replacement face where applicable. Nonconforming signs are subject to the provisions of Section 25.18.09.

25.18.11 – Signs Permitted for Residential Uses in All Zones

The following signs are permitted for residential uses in all zones:

- 1. *Identification Signs* – Each dwelling unit may have permanent occupant identification signs, including a single sign for a valid home-based business enterprise or child care center located on a lot less than 20,000 square feet, in accordance with the following:

- (a) The total aggregate of all such signs must not exceed 150 square inches;
 - (b) The signs may be a building sign or freestanding;
 - (c) If freestanding, the signs must not be illuminated in any manner; and
 - (d) No sign permit is required.
2. *Entrance Signs* – Permanent entrance signs for residential developments or a subdivision containing ten (10) or more dwelling units in accordance with the following:
- (a) One (1) sign not exceeding 24 square feet in area with a maximum height of five (5) feet in height located at or near the entrance to the development or subdivision within the boundaries of such development or subdivision;
 - (b) Where the dwelling units are separately owned, such sign must be located in an easement or tract of land to be owned and/or maintained by the Home Owners Association, civic association, or similar entity;
 - (c) Final location of such sign must be approved by the Director of the Department of Public Works or designee, to ensure that the sign does not obstruct the visibility of motorists; and
 - (d) Such sign must be located in a landscaped area of at least two (2) square feet per each square foot of sign area.
3. *Directional Signs* – Directional signs for residential developments or a subdivision of any size is permitted in accordance with the following:
- (a) Such signs must not exceed three (3) square feet in area; and
 - (b) If freestanding, such signs must not exceed six (6) feet in height.
4. *Temporary Signs* – The following temporary signs:
- (a) *Real Estate Signs for Individual Residential Lots or Dwelling Units*
 - i. One (1) building or freestanding sign per street frontage not exceeding six (6) square feet in area and, if free standing, not exceeding five (5) feet in height, provided that any sign installed within ten (10) feet from the property line must not exceed 42 inches in height;
 - ii. Such signs must not be illuminated; and
 - iii. No sign permit is required.
 - (b) *Real Estate Signs for Recorded Subdivision* – For recorded subdivisions containing ten (10) or more lots, signs must comply with the following:

- i. One (1) sign per subdivision not exceeding 48 square feet in area and, if freestanding, not exceeding 12 feet in height located within the subdivision;
- ii. Such signs must not be illuminated;
- iii. Such signs may be maintained for a period of two (2) years, or until all the lots in the subdivision are sold, whichever occurs first; and
- iv. Sign permits are required and are renewable for such signs.

(c) *Real Estate Signs for New or Renovated Multi-Unit Dwelling Developments*

- i. For developments containing up to ten (10) dwelling units, signs must comply with the following:
 - A. One (1) sign per street frontage not exceeding 12 feet in height located on the property;
 - B. Such signs must not be illuminated; and
 - C. No sign permit is required for such signs.
- ii. For developments containing more than ten (10) dwelling units, signs must comply with the following:
 - A. One (1) sign per street frontage not exceeding 48 square feet in area and, if freestanding, not exceeding 12 feet in height located on the property;
 - B. Such signs must not be illuminated;
 - C. Such signs may be maintained for a period of two (2) years, or until all the units in the development are rented, sold, or leased whichever occurs first; and
 - D. Sign permits are required and are renewable for such signs.

(d) *Temporary Noncommercial Signs*

- i. *General Provisions for Temporary Noncommercial Signs*
 - A. Such signs must not exceed five (5) square feet in area.
 - B. If freestanding, such signs must not exceed five (5) feet in height, provided that any sign installed within ten (10) feet from the property line must not exceed 42 inches in height;
 - C. Such signs must not be illuminated; and
 - D. No sign permit is required for such signs.

- ii. *Yard Sale Signs* – In addition to the general provisions for temporary noncommercial signs provided in Subsection 4.(d)(i), above, property owners holding a yard sale are permitted to erect signs on their own property in accordance with the following:
 - A. Signs must not be displayed for a period longer than two (2) days during any calendar month; and
 - B. Signs must be removed upon the conclusion of the sale.

25.18.12 – Signs Permitted for Nonresidential Uses in Residential Zone

- a. *Signs for Permitted Uses* – For a church, synagogue, or other place of worship and other permitted nonresidential uses in a residential zone, except for child care homes and child care centers located on lots under 20,000 square feet the following signs are permitted in Residential zones:
 - 1. One (1) permanent sign, not exceeding 24 square feet in area for each street frontage
 - (a) If freestanding, it must not be located less than ten (10) feet from any lot line; and
 - (b) The sign may contain changeable copy.
 - 2. Directional signs, provided that:
 - (a) Such signs do not exceed three (3) square feet in area; and
 - (b) If freestanding, such signs must not exceed six (6) feet in height.
- b. *Signs for Special Exceptions* – For non-residential special exception uses in residential zones:
 - 1. All signs shall be as permitted by the Board of Appeals in its approval of the special exception application, except that the Board of Appeals may not permit any sign prohibited under Section 25.18.04.
 - 2. Residential special exceptions valid on December 31, 1983 have the following options:
 - (a) One (1) sign not exceeding 20 square feet in area is allowed. It may be a building sign or freestanding. If freestanding, the sign must not exceed five (5) feet in height; or
 - (b) A qualified applicant may apply to the Board of Appeals for an amendment to existing sign conditions in compliance with Section 25.15.01.b.
- c. *Temporary Real Estate Signs* – Temporary real estate signs are permitted for all nonresidential uses in residential zones in accordance with the provisions of Section 25.18.11.4.(a).

- d. *Temporary Noncommercial Signs* – Temporary noncommercial signs are permitted in accordance with the provisions of Section 25.18.11.4.(d).

25.18.13 – Signs Permitted in MXC and Industrial Zones

- a. *Permanent Building Signs* – Permanent building signs are permitted in the Mixed-Use Commercial (MXC) and Industrial (I-L and I-H) Zones in accordance with the following:

- 1. *Total Aggregate Area*

- (a) The total aggregate area of all signs on the premises allowed for each business/tenant must not exceed:
 - i. Two (2) square feet for each linear foot of exterior building wall enclosing the business/tenant space up to a maximum of 50 square feet.
 - ii. If such building wall or portion thereof measures more than 50 linear feet, then the aggregate area of all signs on the premises for that business/tenant may be increased in area at the rate of one (1) square foot for each linear foot of exterior building wall in excess of 50 linear feet.

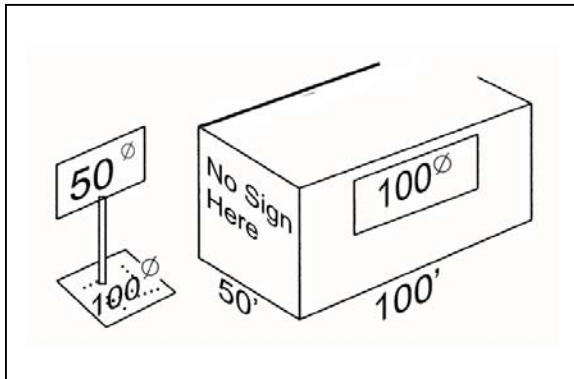

Total Aggregate Area for Each Business/Tenant

Figure 18.6

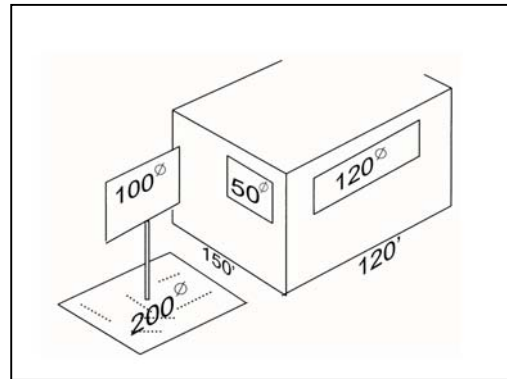

Figure 18.7

- (b) For business/tenant space with multiple exterior building walls, each exterior wall may be so measured. All signs must be placed on the exterior building wall or portion thereof used for measurement.

- 2. *Design*

- (a) For a lot occupied by more than one (1) business/tenant, each building sign must be compatible and harmonious (but not necessarily identical) in terms of

design, color, shape, size, style, material, and mounting with all other signs on the building or in the center.

- (b) A proposal for the entire building or center must be submitted by the owner prior to the issuance of the first sign permit after the effective date of this Article for either a new or existing development.

- 3. *Additional Signs for Multiple Tenants* – Buildings occupied by four (4) or more businesses/tenants may have one (1) additional building sign with a maximum area of 50 square feet located on an exterior wall.

b. *Freestanding Signs*

- 1. Freestanding signs are permitted in the Mixed-Use Commercial (MXC) Zone in accordance with the following:
 - (a) One (1) freestanding sign is permitted per record lot;
 - (b) Such sign must not exceed a maximum area of 50 square feet and a maximum height of six (6) feet;
 - (c) Such sign must not use internal illumination;
 - (d) Such sign must not be located within ten (10) feet from any lot line;
 - (e) A landscaped area must be provided at the base of the freestanding sign, with the landscaped area to be a minimum area of two (2) square feet of sign area; and
 - (f) Freestanding signs that contain the name, logo, or trademark of more than one (1) business, place, organization, building, or person must meet the following requirements in addition to those listed above:
 - i. Lettering for the identification of the building/center must not be less than 18 inches in height;
 - ii. Lettering for the identification of individual businesses/tenants and other copy must not be less than ten (10) inches in height;
 - iii. The design of the sign shall be internally consistent and harmonious in color, size, style, material, and mounting; and
 - iv. The design of the sign shall be consistent and harmonious with the sign plan and architecture for the entire building or center.

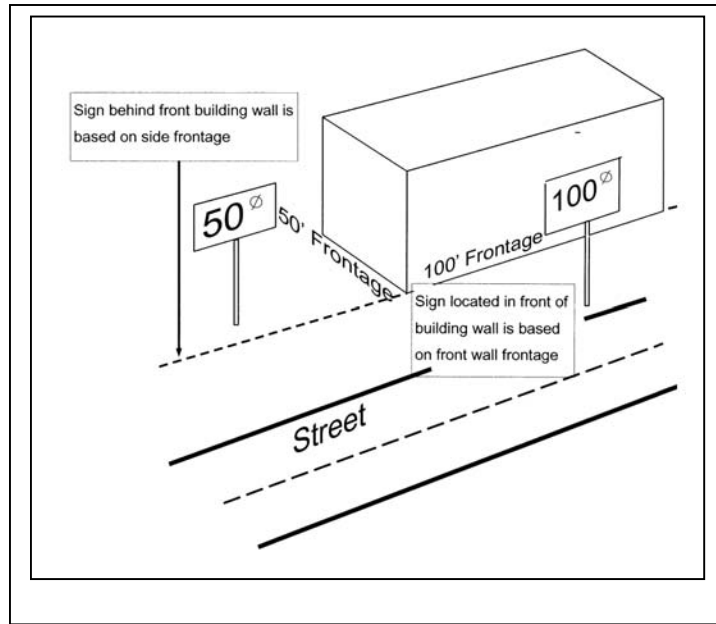

Figure 18.8 - Freestanding Signs

2. Freestanding signs are permitted in the I-L and I-H Zones in accordance with the following:
 - (a) Freestanding signs that identify a single business/tenant shall be counted as a portion of the total aggregate sign area allowed for that business/tenant.
 - (b) Other freestanding signs, including those that identify a multi-tenant building or center, shall not be counted in the aggregate sign area allowed for any individual business/tenant. Such signs must be in accordance with the following:
 - i. There shall be only one (1) freestanding sign per record lot;
 - ii. Such signs must have a maximum area of 50 square feet and a maximum height of ten (10) feet;
 - iii. The freestanding sign must be counted as a portion of the aggregate sign area of the most proximate exterior building wall;
 - iv. Such signs must not be closer than 30 feet to any residential zone; and
 - v. Freestanding signs that contain the name, logo, or trademark of more than one (1) business, place, organization, building, or person must, in addition to the requirements above, satisfy the following additional requirements:
 - A. Lettering for the identification of the building/center must not be less than 18 inches in height;

- B. Lettering for the identification of individual businesses/tenants and other copy must not be less than ten (10) inches in height;
- C. The design of the sign must be internally consistent and harmonious in color, size, style, material, and mounting; and
- D. The design of the sign must be consistent and harmonious with the sign plan and architecture for the entire building or center.

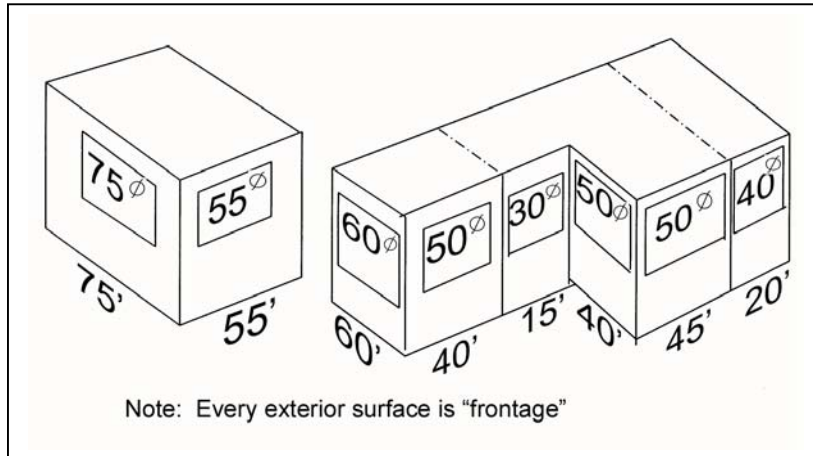

Figure 18.9 - Building Signs (2)

- c. *Additional Signs* – Additional signs are permitted in Mixed-Use Neighborhood Commercial (MXNC), Mixed-Use Commercial (MXC), and Industrial (I-L and I-H) Zones in accordance with the following:
 1. Buildings or centers occupied by four (4) or more businesses/tenants may have one (1) additional sign, with one (1) entry per business/tenant.
 2. Letters must be a maximum height of three (3) inches and must be consistent in style.
 3. Such sign may be erected as a building sign or freestanding sign not intended to be readable from a public way.
 4. If freestanding, such sign must not exceed a maximum of 50 square feet in area and a maximum height of ten (10) feet.
- d. *Directional Signs* – Directional signs in the Mixed-Use Neighborhood Commercial (MXNC), Mixed-Use Commercial (MXC), and Industrial (I-L and I-H) Zones are permitted in accordance with the following:
 1. The sign must not exceed three (3) square feet in area; and

2. If freestanding, the sign must not exceed six (6) feet in height.
- e. *Gasoline Price Signs* – In the Mixed-Use Neighborhood Commercial (MXNC), Mixed-Use Commercial (MXC), and Industrial (I-L and I-H) Zones, gasoline price signs required by State law for automobile filling stations may be freestanding or erected as a building sign. Any such sign or portion thereof that exceeds the minimum requirements of State law must be counted in the number, size, and total aggregate area for the business/tenant.
 - f. *Changeable Copy Signs* – Changeable copy signs are permitted in the Mixed-Use Neighborhood Commercial (MXNC), Mixed-Use Commercial (MXC) and Industrial (I-L and I-H) Zones to announce current and future entertainment productions. Such sign may be freestanding and shall be counted in the number, size, and aggregate sign area permitted for the business/tenant.
 - g. *Temporary Signs* – Temporary signs are permitted in the Mixed-Use Neighborhood Commercial (MXNC), Mixed-Use Commercial (MXC) and Industrial (I-L and I-H) Zones in accordance with the following:
 1. One (1) real estate sign per lot not exceeding 48 square feet in area, and not more than 12 feet in height if freestanding, or one (1) building sign not exceeding 72 square feet in area if mounted at least 70 feet above adjacent grade, in accordance with the following:
 - (a) Such signs must not be illuminated;
 - (b) Such signs may be maintained for a period of two (2) years or until the building or lot is rented, leased, or sold, whichever occurs first. Signs must be removed within 30 days after sale, lease, or rental. Signs installed for a two (2) year renewal period are limited to a maximum size of 24 square feet; and
 - (c) Such signs must not be located within 30 feet of a residential zone.
 2. One (1) sign may be erected during the period of construction with a total maximum sign area of 72 square feet.
 3. Upon occupancy of a space by a business or tenant, banners, and displays not exceeding 32 square feet in total area may be erected for up to 60 consecutive days including days before or after actual occupancy date by the business or tenant.
 4. Temporary noncommercial signs are permitted in the Mixed-Use Commercial (MXC) and Industrial (I-L and I-H) zones in accordance with the provisions of Section 25.18.14.a.4.(b).
 - h. *Subdivision Entrance Signs* – In the Industrial zones, permanent signs within recorded subdivisions of four (4) or more lots are permitted in accordance with the following:
 1. One (1) sign is permitted, not exceeding 50 square feet in area and not exceeding six (6) feet in height.
 2. Such sign must be located at or near the entrance to the subdivision within the boundaries of the subdivision.

3. Final location of such sign must be approved by the City Traffic Engineer to ensure that the sign does not obstruct the visibility of motorists.
4. Such sign must be located in a landscaped area of at least two (2) square feet per each square foot of sign area.
5. Such sign must not use internal illumination.

25.18.14 - Signs Permitted in Other Mixed-Use Zones

- a. The following signs are permitted in the MXT Zone:
 1. Permanent building signs in accordance with the following:
 - (a) The total area of all building signs must not exceed 15 square feet on any building;
 - (b) Such signs must not utilize internal illumination; and
 - (c) Such signs must not be placed above the first-story level of any building;
 2. Permanent freestanding signs in accordance with the following:
 - (a) One (1) freestanding sign is permitted for each record lot or project not exceeding eight (8) square feet in area and not exceeding five (5) feet in height;
 - (b) Such sign must not utilize internal illumination; and
 - (c) Such sign must be located not less than ten (10) feet from a lot line of any lot used principally for a residence;
 3. Directional signs in accordance with the following:
 - (a) Such sign must not to exceed three (3) square feet in area; and
 - (b) If freestanding, not to exceed six(6) feet in height;
 4. Temporary signs in accordance with the following:
 - (a) One (1) real estate sign per lot not exceeding 24 square feet in area and eight (8) feet in height, in accordance with the following:
 - i. Such signs must not be illuminated;
 - ii. Such signs may be maintained for a period of two (2) years or until the building or lot is rented, leased, sold, whichever occurs first; and
 - iii. Such signs must not be located within 30 feet of a residential zone.
 - (b) Temporary noncommercial signs are permitted in accordance with the following:

- i. The total aggregate area of all such signs on a single lot must not exceed 32 square feet;
 - ii. No single sign may exceed 12 square feet in size;
 - iii. If freestanding, such signs must not exceed eight (8) feet in height;
 - iv. In lieu of the signage allowed in subsection (b)(i) and (ii) above, on any record lot that abuts a limited access highway noncommercial temporary signs may be attached to the side of a building facing a limited access highway. Such signs must be mounted to the top floor face of the building, must not obstruct windows, and must not exceed an aggregate size of 100 square feet.
 - v. Such signs must not be illuminated;
 - vi. Such signs must not be located within 30 feet of a residential zone;
 - vii. No sign permit is required for such signs.
- b. Signs permitted in the MXTD, MXCD, MXNC, MXB, and MXE Zones:
- 1. *Permanent Building Signs* - Permanent building signs are permitted in the MXTD, MXCD, MXB, and MXE Zones in accordance with the following:
 - (a) *MXTD and MXCD Zones*
 - i. The total aggregate area of all signs on the premises allowed for each business/tenant must not exceed:
 - A. Two (2) square feet for each linear foot of exterior building wall enclosing the business/tenant space up to a maximum of 50 square feet.
 - B. If such building wall or portion thereof measures more than 50 linear feet, then the aggregate area of all signs on the premises for that business/tenant may be increased in area at the rate of one (1) square foot for each linear foot of exterior building wall in excess of 50 linear feet.
 - ii. For a lot occupied by more than one (1) business/tenant, each building sign must be consistent and harmonious in terms of design, color, shape, size, style, material, and mounting with other such signs on the building or in the center. A proposal for the entire building or center must be submitted by the owner prior to the issuance of the first sign permit for either a new or existing development.
 - iii. In the MXTD Zone, signs allowed for an individual business/tenant in a multi-tenant building must be placed only on pedestrian levels of the building.

- iv. In addition to the above, buildings occupied by two (2) or more businesses/tenants may have building signs with a maximum area of 50 square feet each located on any exterior wall that has frontage on the public right-of-way.

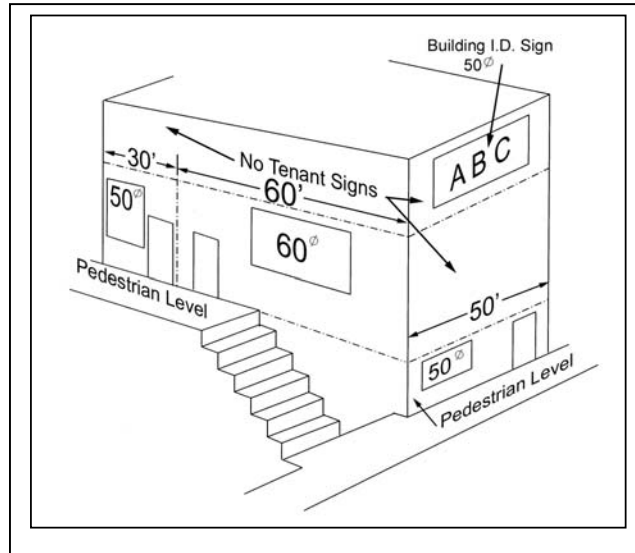

Figure 18.10 - Building Signs (1)

- v. One (1) small, portable "sandwich board" sign may be allowed as follows:
 - A. The sign must be located directly in front the business to which it refers;
 - B. Each sign face cannot exceed four (4) square feet in area; and
 - C. The sign must not be placed where it will impede pedestrian traffic on the sidewalk, nor can it be placed in such a way as to impede vehicle traffic.
- (b) *Total Aggregate Area – MXE and MXB Zones*
 - i. The total area of all signs erected on a record lot in the MXE and MXB Zones must not exceed 250 square feet.
 - ii. For a lot occupied by more than one (1) business/tenant, each building sign must be consistent and harmonious in terms of design, color, shape, size, style, material, and mounting with other such signs on the building or in the center. A proposal for the entire building or center must be submitted

by the owner prior to the issuance of the first sign permit for either a new or existing development.

- (c) *Optional Comprehensive Sign Package* – An applicant for new development or comprehensive redevelopment of a multi-tenant project may submit a comprehensive sign program to the Sign Review Board that deviates from the above requirements of subsection b.1, above.
 - i. The Sign Review Board may approve such a comprehensive sign package provided that:
 - A. If the maximum size otherwise allowed for any sign is increased, the total square footage of all signs on the project must not exceed the maximum aggregate total signage area permitted in ~~this~~ subsection b.1, above.
 - B. Notwithstanding any variation among the signs in design, color, shape, size, style, material, or mounting, the signs must be compatible with each other and with the surrounding properties.
 - ii. In reviewing a proposed comprehensive sign package, the Sign Review Board must consider:
 - A. The size, shape, color, design elements, and location of the signs;
 - B. The compatibility of the proposed signs with the surrounding properties, the proximity of other signs, and the characteristics of the area where the signs are to be located; and
 - C. Any recommendations from the Chief of Planning or the Planning Commission.
 - iii. The Sign Review Board may impose such conditions and terms when approving a comprehensive sign package, that are reasonably necessary to satisfy the purpose and intent of this Article.

2. *Freestanding Signs*

- (a) Freestanding signs are permitted in the MXTD Zone in accordance with the following:
 - i. One (1) freestanding sign is permitted per record lot;
 - ii. Such sign must not exceed a three (3) feet by eight (8) inches with a maximum height of six (6) feet;
 - iii. Such sign must not use internal illumination;
 - iv. Such sign must not have a separate supporting structure; and

- v. Final location of such sign must be approved by the Director of the Department of Public Works, or their designee, to ensure motorist visibility.
 - vi. Freestanding signs may also be subject to the provisions of Sec. 25.17.08.d for areas along Rockville Pike.
- (b) Freestanding signs are permitted in the MXCD and MXNC Zones in accordance with the following:
- i. Freestanding signs that identify a single business/tenant must be counted as a portion of the total aggregate sign area allowed for that business/tenant. Other freestanding signs, including those that identify a multi-tenant building or center, must not be counted in the aggregate sign area allowed for any individual business/tenant. Such signs must be in accordance with the following:
 - A. One (1) freestanding sign for each record lot. On record lots larger than five (5) acres, one (1) freestanding sign shall be permitted on each street frontage on a major highway or business district street. Where more than one (1) freestanding sign is permitted, they shall be erected at least 100 feet apart;
 - B. Such signs must not exceed a maximum area of 100 square feet and a maximum height of 20 feet, provided that the area of a freestanding sign must not exceed the aggregate sign area allowed for the premises as measured by the most proximate building wall;
 - C. The freestanding sign shall be counted as a portion of the aggregate sign area of the most proximate exterior building wall;

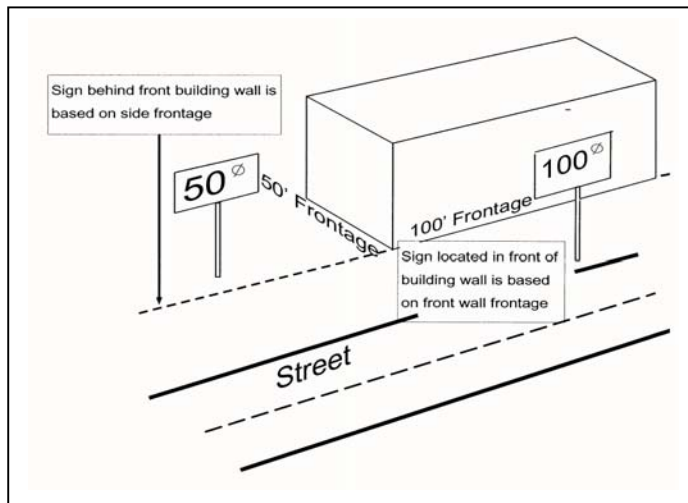

Figure 18.11 - Freestanding Signs

- D. Such signs must not be closer than 30 feet to any residential zone;

- E. A landscaped area must be provided at the base of the freestanding sign, with the landscaped area a minimum area of two (2) square feet for each square foot of sign area;
 - F. The design of the sign shall be compatible and harmonious with the sign plan and architecture for the entire building or center; and
 - G. Freestanding signs are also subject to the provisions of Sec. 25.17.08.c for areas along Rockville Pike.
- ii. Freestanding signs that contain the name, logo, or trademark of more than one (1) business, place, organization, building, or person must satisfy the requirements set forth in subsections b.2.(b)(i)A. through F. of this Section, 25.18.14, plus the following additional requirements:
- A. Lettering for the identification of the building/center must not be less than 18 inches in height;
 - B. Lettering for the identification of individual businesses/tenants and other copy must not be less than ten (10) inches in height;
 - C. The design of the sign must be internally consistent and harmonious in color, size, style, material, and mounting; and
 - D. The design of the sign must be consistent and harmonious with the sign plan and architecture for the entire building or center.

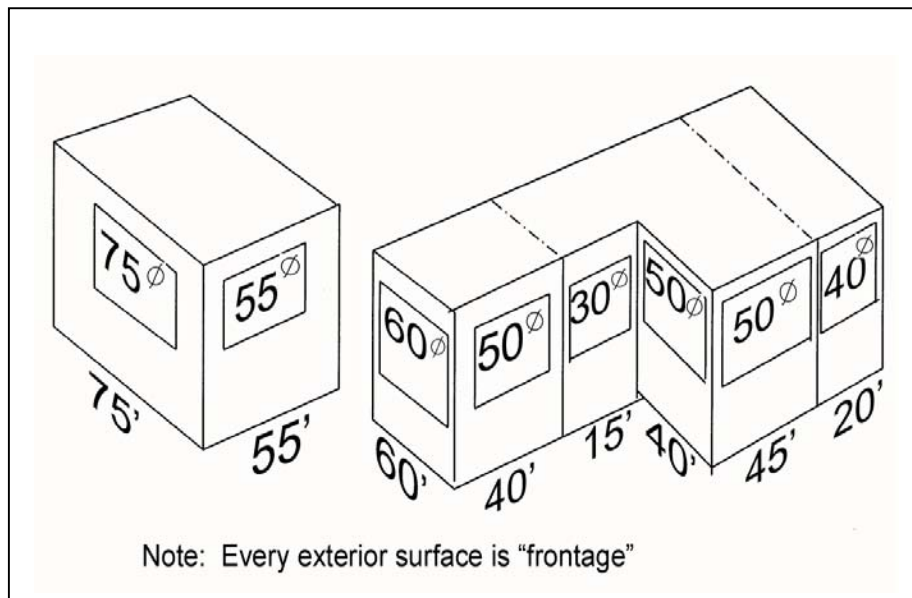
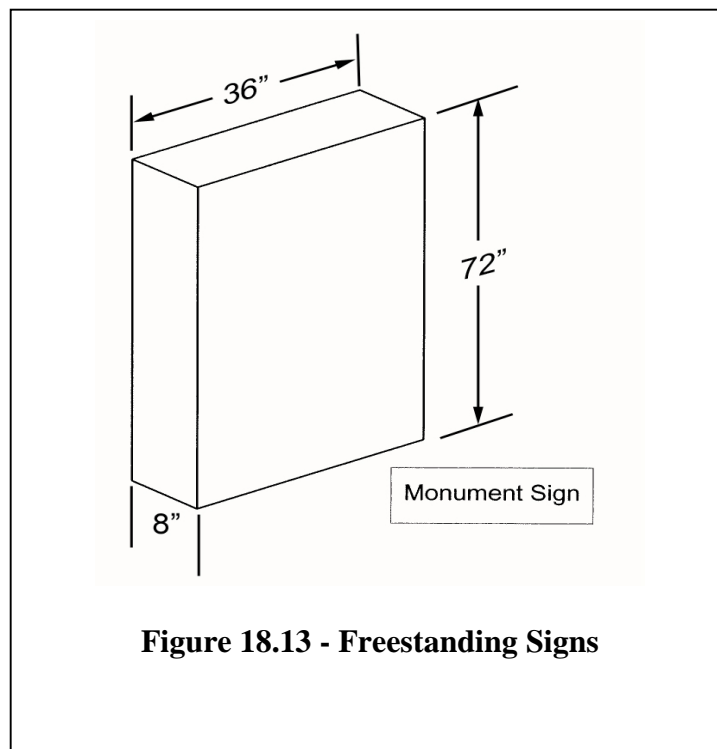

Figure 18.12 - Building Signs

- (c) Freestanding signs are permitted in the MXE Zone in accordance with the following:
- i. Freestanding signs must be counted as a portion of the total aggregate sign area of the lot;
 - ii. One (1) freestanding sign for each record lot not exceeding 100 square feet in area and not exceeding 20 feet in height is allowed. Such sign must be located not less than 50 feet from any lot line;
 - iii. In addition, record lots which abut a limited access highway may have one (1) additional freestanding sign not exceeding 50 square feet in area and not exceeding five (5) feet in height to be located at the principal point of ingress to such lot and not less than ten (10) feet from any lot line;
 - iv. A landscaped area must be provided at the base of the freestanding sign. The landscaped area must be a minimum area of two (2) square feet for each square foot of sign area; and
 - v. Letters and graphics on such signs must not exceed six (6) inches in height.



3. *Directional Signs* – Directional signs are permitted in accordance with the following:
- (a) The sign must not exceed three (3) square feet in area; and

- (b) If freestanding, the sign must not exceed six (6) feet in height.
4. *Gasoline Price Signs* – Gasoline price signs required by State law for automobile filling stations may be freestanding or erected as a building sign. Any such sign or portion thereof that exceeds the minimum requirements of State law must be counted in the number, size, and total aggregate area for the business/tenant.
 5. *Changeable Copy Signs* – Changeable copy signs are permitted to announce current and future entertainment productions. Such sign may be freestanding and shall be counted in the number, size, and aggregate sign area permitted for the business/tenant.
 6. *Temporary Signs* – Temporary signs are permitted in the Mixed-Use Transit District Zone (MXTD), Mixed-Use Corridor District (MXCD), Mixed-Use Business District (MXB), and Mixed-Use Employment (MXE) Zones in accordance with the following:
 - (a) One (1) real estate sign is permitted per lot not exceeding 48 square feet in area, and not more than 12 feet in height if freestanding, or one (1) building sign not exceeding 72 square feet in area if mounted at least 70 feet above adjacent grade, in accordance with the following:
 - i. Such signs must not be illuminated;
 - ii. Such signs may be maintained for a period of two (2) years or until the building or lot is rented, leased, or sold, whichever occurs first. Signs must be removed within 30 days after sale, lease, or rental. Signs installed for a two (2) year renewal period are limited to a maximum size of 24 square feet; and
 - iii. Such signs must not be located within 30 feet of a residential zone.
 - (b) One (1) sign may be erected during the period of construction with a total maximum sign area of 72 square feet.
 - (c) Upon occupancy of a space by a business or tenant, banners, and displays not exceeding 32 square feet in total area may be erected for up to 60 consecutive days including days before or after actual occupancy date by the business or tenant.
 - (d) Temporary noncommercial signs are permitted in the MXTD, MXCD, MXB, and MXE Zones in accordance with the provisions of Section 25.18.14.a.4.(b).

25.18.15 – Election Signs

- a. *Residential Zones / Residential Property in Other Zones* – In residential zones and on residential property in all zones, election signs must comply with the size, height, and location requirements for temporary noncommercial signs contained in Sections 25.18.11.4(d).
 1. Such signs are subject to applicable provisions of Section 25.18.04.

2. No sign permit is required.
- b. *All Other Zones* – In all other zones, election signs must comply with the requirements of the zone in which it is located pertaining to the size, area, height, duration, and location requirements for temporary noncommercial signs.
 1. Such signs are subject to applicable provisions of Section 25.18.04.
 2. No sign permit is required.
- c. *Removal* – Election signs that are no longer needed should be removed within seven (7) days after the election to which they pertain. It shall be the obligation of the candidate to cause all such signs to be removed prior to the expiration of the period.
- d. *No Illumination* – Election signs must not be illuminated.
- e. *Usage of Permanent Sign* – Nothing herein precludes the usage at any time of permanent signage permitted under this Article to advocate a candidate or issue to be voted on in an election.

25.18.16 – Signs on Public Property and the Public Right-of-Way

- a. *Signs Prohibited* – No sign is permitted on public property or within the public right-of-way except as directed or authorized by the City Manager.
- b. *Exceptions* – The City Manager may direct or authorize the erection of one (1) or more of the following signs on public property or within the public right-of-way:
 1. Traffic control signs;
 2. Signs that provide directional or other public service information;
 3. Signs pertaining to a governmental or public purpose;
 4. Signs pertaining to the use, maintenance, and/or operation of public property or right-of-way and/or pertaining to any events or activities lawfully conducted on said property or right-of-way;
 5. Signs pertaining to the closure or partial closure of a road or other public right-of-way; and
 6. Such other signs deemed to be in the public interest.
- c. *Community Events and Noncommercial Messages* – The City Manager may designate one (1) or more areas on public property or within the public right-of-way for the erection of signs pertaining to publicly and/or privately sponsored community events and noncommercial messages. Such signs must be erected and maintained in accordance with such standards, requirements, and conditions as may be established by the City Manager.

25.18.17 – Noncommercial Signs in Lieu of Commercial Signs

Notwithstanding any provision of this Article or Chapter to the contrary, any sign permitted by this Article or Chapter to contain a commercial message may, in lieu thereof, contain a noncommercial message unrelated to the business, tenant, or entity located on the premises where the sign is erected, provided that the other criteria and regulations contained in this Article and Chapter have been satisfied, including but not limited to size, height, setback, location, duration, design, maintenance, and construction regulations and criteria.