

APPENDIX A ROLLINS AVENUE FIELD VISIT NOTES

ROLLINS AVENUE FIELD VISIT

Date: 1/8/2026

Time: 10 AM – 12 Noon

Attendees:

- Bryan Barnett-Woods (City of Rockville)
- Elizabeth Woodward (City of Rockville)
- Aditya Inamdar (Kittelson)
- Deema Allen (T3)

Description:

The group walked on both sides of the Rollins Avenue corridor from cul-de-sac, just west of Evelyn Drive/Martha Terrace to MD 355 (Rockville Pike). Observations were made regarding existing conditions, especially pedestrian crosswalks, ramps, sidewalks, and roadway widths. The group discussed potential traffic calming treatments and safety improvements for pedestrian and bicycle facilities.

Field Notes:

Land Use

- Montrose Park is a City-owned park and is very well utilized by the community. The Park includes a community center and run daycare center.
- Corridor has two distinct context zones/segments.
 - Cul-de-sac to Jefferson Street is residential. Apart from one multi-family garden-style apartment complex on the north side of Rollins Avenue between Jefferson Street and Congressional Lane/Lorraine Drive, all other properties have post-war single-family detached housing.
 - Jefferson Street to MD 355 is a mixed-use segment with a mix of medium rise to high-rise multi-family residential buildings, suburban strip commercial centers, fire station, and a mixed-use urban style apartment building.
- Old Farm Creek is located west of the cul-de-sac and is the City limit. Due to topographic changes, any ped/bike connections beyond the cul-de-sac seem infeasible.
- Explore opportunities to enhance access for fire engines at fire stations. Restrict parking or move stop bars, etc.

Existing Street Conditions

- Total Curb face to curb face width is about forty feet. Two twelve-foot lanes and two eight-foot parking lanes.
- Total asphalt width (Gutter Pan to Gutter Pan) is thirty-seven feet.
- Stormwater raingarden exists at the cul-de-sac.
- Existing sidewalks from cul-de-sac to Fire station are four feet wide with a ten-foot landscape buffer with street trees.

- The City's standard is five-foot sidewalks. There is potential to recommend wider sidewalks when street/sidewalks are reconstructed or recommend wider crossing points at equal intervals.
- Eight-foot sidewalks with seven-foot landscape buffers exist between fire station and MD 355 on the north side. Similar condition exists in front of Rollins Ridge Apartments on the south side, just west of MD 355.
- There are two-foot curbs and gutters located on both sides. This includes a six-inch curb and one-foot six-inch gutter pan that is part of on-street parking.
- Eight-foot parking (including six-inch to one-foot gutter pan) is located on both sides. Parking is generally restricted to permit holders.
- West of Jefferson Street Rollins Ave has two twelve-foot lanes separated by double-yellow striping.
- There are overhead utilities and utility poles on south-side of the corridor within the landscape buffer.
- The yield control for Martha Terrace T-intersection with Rollins is unusual, as this type of intersection would be stop-controlled.
- Refer to Rockville Street Standards when developing recommendations.

Crosswalks and Ramps

- The City restriped most of the crosswalks as continental high-visibility crosswalks as part of resurfacing project. The City uses SHA guidance regarding crosswalk markings. The resurfacing project only replaced existing crosswalks as continental high-visibility crosswalks. They did not add new crosswalks.
- Several ramps at intersection are bi-directional ramps that lead pedestrians to the middle of the intersection. Potential opportunity to recommend redesigning ramps to be two separate directional ramps guiding pedestrians across individual intersection legs.
- There is a demand for mid-block pedestrian crossing activity at 7-11 and Federal Plaza, just west of USPS Post Office. The City would like to explore formalizing a mid-block pedestrian crossing at this location.
- Explore options to add refuge island/nosing to crosswalks at MD 355.
- Explore other locations to add crosswalks along the corridor, especially across Rollins Avenue.

Bicycle Facilities

- The City's Master Plan recommends shared lanes.
- The City would not like to add bike lanes on residential streets, rather approach full residential neighborhoods as slow streets zone and design a network of traffic calmed shared streets.
- Parking should be maintained in the residential segment.
- Potential bike boulevard/Neighborway treatment like Sharrows with traffic calming treatments such as curb extensions, refuge islands, raised crosswalks/speed humps, etc.
- In Mixed Use Segment between Jefferson Street and MD 355 – explore opportunities to add bike lanes by narrowing east-bound twenty-foot-wide lane (parking is restricted but curb to curb width is same as the rest of the corridor.) Maintain through lane and left-turn lane in west-bound direction.

- To continue bicycle lanes till MD 355, explore restricting on-street parking between Jefferson Street and MD 355 for a short stretch where parking is permitted between USPS Post office and Rollins Ridge Apartments.
- Explore reducing lengths of turn lanes based on traffic analysis.

Safety

- Analyze crash patterns to identify safety improvements rather than rely on traffic operations analysis since the corridor does not have heavy traffic.
- Collect SHA crash data and request more detailed crash data at specific intersections if required.

Upcoming Projects

- The City is working on bicycle facilities on Jefferson Street and Congressional Lanes. Incorporate those designs in recommendations for Rollins Avenue.
- MCDOT is working on MD 355 Flash BRT project. Incorporate those designs in recommendations for Rollins and MD 355 BRT

APPENDIX B SYSTEMWIDE PEAK HOUR

Systemwide Peak Hour						Total
Time	Rollins and Mall	Rollins and Jefferson	Rollins and Martha	Rollins and Rockville	Rollins and Congressional	Volume
AM Peak						
8:00:00 AM	741	1148	135	3397	221	5642
8:15:00 AM	757	1139	130	3402	224	5652
8:30:00 AM	777	1152	139	3397	248	5713
8:45:00 AM	799	1196	137	3346	251	5729
9:00:00 AM	808	1199	129	3288	239	5663
9:15:00 AM	806	1193	121	3248	208	5576
9:30:00 AM	789	1162	110	3247	188	5496
9:45:00 AM	821	1166	105	3394	181	5667
10:00:00 AM	840	1196	107	3427	186	5756
PM Peak						
3:00:00 PM	1211	1744	151	4415	284	7805
3:15:00 PM	1220	1770	153	4525	285	7953
3:30:00 PM	1243	1796	154	4567	284	8044
3:45:00 PM	1264	1832	153	4726	271	8246
4:00:00 PM	1235	1843	149	4704	269	8200
4:15:00 PM	1237	1911	159	4727	293	8327
4:30:00 PM	1245	1917	170	4737	322	8391
4:45:00 PM	1237	1954	186	4696	345	8418
5:00:00 PM	1225	1936	207	4678	362	8408
5:15:00 PM	1177	1829	197	4580	354	8137
5:30:00 PM	1128	1720	184	4433	329	7794
5:45:00 PM	1046	1579	163	4198	302	7288
6:00:00 PM	1006	1484	149	4030	295	6964

APPENDIX C EXISTING SYNCHRO OUTPUT REPORTS

Queues
3: East Jefferson St & Rollins Ave

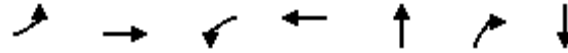

Lane Group	EBL	EBT	WBL	WBT	NBT	NBR	SBT
Lane Group Flow (vph)	10	39	269	70	392	334	256
v/c Ratio	0.09	0.28	0.77	0.21	0.38	0.24	0.14
Control Delay	35.4	28.2	44.8	11.9	13.5	2.6	10.4
Queue Delay	0.0	0.0	0.0	0.0	0.0	0.0	0.0
Total Delay	35.4	28.2	44.8	11.9	13.5	2.6	10.4
Queue Length 50th (ft)	5	11	128	8	111	32	31
Queue Length 95th (ft)	17	35	184	35	213	63	63
Internal Link Dist (ft)		1000		777	823		684
Turn Bay Length (ft)			250				
Base Capacity (vph)	203	244	597	540	1034	1366	1857
Starvation Cap Reductn	0	0	0	0	0	0	0
Spillback Cap Reductn	0	0	0	0	0	0	0
Storage Cap Reductn	0	0	0	0	0	0	0
Reduced v/c Ratio	0.05	0.16	0.45	0.13	0.38	0.24	0.14
Intersection Summary							

HCM Signalized Intersection Capacity Analysis
3: East Jefferson St & Rollins Ave

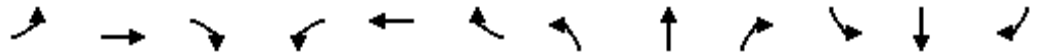

Movement	EBL	EBT	EBR	WBL	WBT	WBR	NBL	NBT	NBR	SBL	SBT	SBR
Lane Configurations												
Traffic Volume (vph)	8	18	14	237	17	45	12	329	291	13	201	11
Future Volume (vph)	8	18	14	237	17	45	12	329	291	13	201	11
Ideal Flow (vphpl)	1900	1900	1900	1900	1900	1900	1900	1900	1900	1900	1900	1900
Total Lost time (s)	5.5	5.5		5.0	5.0			6.0	6.0		6.0	
Lane Util. Factor	1.00	1.00		1.00	1.00			1.00	1.00		0.95	
Frt	1.00	0.93		1.00	0.89			1.00	0.85		0.99	
Flt Protected	0.95	1.00		0.95	1.00			1.00	1.00		1.00	
Satd. Flow (prot)	1444	1627		1770	1501			1826	1583		3479	
Flt Permitted	0.95	1.00		0.95	1.00			0.99	1.00		0.93	
Satd. Flow (perm)	1444	1627		1770	1501			1805	1583		3235	
Peak-hour factor, PHF	0.83	0.83	0.83	0.88	0.88	0.88	0.87	0.87	0.87	0.88	0.88	0.88
Adj. Flow (vph)	10	22	17	269	19	51	14	378	334	15	228	12
RTOR Reduction (vph)	0	16	0	0	41	0	0	0	0	0	3	0
Lane Group Flow (vph)	10	23	0	269	29	0	0	392	334	0	253	0
Heavy Vehicles (%)	25%	0%	21%	2%	0%	2%	0%	4%	2%	0%	3%	0%
Parking (#/hr)					0							
Turn Type	Split	NA		Split	NA		Perm	NA	pt+ov	Perm	NA	
Protected Phases	4	4		3	3			2	2 3		6	
Permitted Phases							2				6	
Actuated Green, G (s)	4.0	4.0		15.8	15.8			43.7	65.5		43.7	
Effective Green, g (s)	4.0	4.0		15.8	15.8			43.7	65.5		43.7	
Actuated g/C Ratio	0.05	0.05		0.20	0.20			0.55	0.82		0.55	
Clearance Time (s)	5.5	5.5		5.0	5.0			6.0			6.0	
Vehicle Extension (s)	2.0	2.0		1.0	1.0			5.0			5.0	
Lane Grp Cap (vph)	72	81		349	296			985	1296		1767	
v/s Ratio Prot	0.01	c0.01		c0.15	0.02				0.21			
v/s Ratio Perm								c0.22			0.08	
v/c Ratio	0.14	0.28		0.77	0.10			0.40	0.26		0.14	
Uniform Delay, d1	36.4	36.6		30.4	26.3			10.5	1.7		8.9	
Progression Factor	1.00	1.00		1.00	1.00			1.00	1.00		1.00	
Incremental Delay, d2	0.3	0.7		9.2	0.1			1.2	0.0		0.2	
Delay (s)	36.7	37.3		39.6	26.3			11.7	1.7		9.1	
Level of Service	D	D		D	C			B	A		A	
Approach Delay (s)		37.2			36.9			7.1			9.1	
Approach LOS		D			D			A			A	

Intersection Summary

HCM 2000 Control Delay	15.9	HCM 2000 Level of Service	B
HCM 2000 Volume to Capacity ratio	0.48		
Actuated Cycle Length (s)	80.0	Sum of lost time (s)	16.5
Intersection Capacity Utilization	62.1%	ICU Level of Service	B
Analysis Period (min)	15		













c Critical Lane Group

Queues
5: Rockville Pike & Twinbrook Pkwy



Lane Group	EBT	WBT	WBR	NBL	NBT	NBR	SBL	SBT
Lane Group Flow (vph)	336	375	186	108	1089	162	164	1251
v/c Ratio	0.58	0.63	0.68	0.33	0.35	0.16	0.43	0.39
Control Delay	60.5	61.8	70.3	9.8	14.8	2.5	10.3	14.5
Queue Delay	0.0	0.0	0.0	0.0	0.0	0.0	0.0	0.0
Total Delay	60.5	61.8	70.3	9.8	14.8	2.5	10.3	14.5
Queue Length 50th (ft)	161	182	173	27	176	0	42	202
Queue Length 95th (ft)	200	204	224	57	257	35	83	290
Internal Link Dist (ft)	203	744			712			906
Turn Bay Length (ft)			100	150		290	350	
Base Capacity (vph)	835	861	392	425	3119	1013	465	3184
Starvation Cap Reductn	0	0	0	0	0	0	0	0
Spillback Cap Reductn	0	0	0	0	0	0	0	0
Storage Cap Reductn	0	0	0	0	0	0	0	0
Reduced v/c Ratio	0.40	0.44	0.47	0.25	0.35	0.16	0.35	0.39
Intersection Summary								

HCM Signalized Intersection Capacity Analysis
5: Rockville Pike & Twinbrook Pkwy

												
Movement	EBL	EBT	EBR	WBL	WBT	WBR	NBU	NBL	NBT	NBR	SBU	SBL
Lane Configurations		↑↑			↑↑	↑			↑↑↑	↑		↑
Traffic Volume (vph)	0	243	90	0	315	156	27	71	991	147	11	150
Future Volume (vph)	0	243	90	0	315	156	27	71	991	147	11	150
Ideal Flow (vphpl)	1900	1900	1900	1900	1900	1900	1900	1900	1900	1900	1900	1900
Total Lost time (s)		7.5			7.5	7.5		7.0	5.5	5.5		7.0
Lane Util. Factor		0.95			0.95	1.00		1.00	0.91	1.00		1.00
Frt		0.96			1.00	0.85		1.00	1.00	0.85		1.00
Flt Protected		1.00			1.00	1.00		0.95	1.00	1.00		0.95
Satd. Flow (prot)		3435			3539	1615		1785	4988	1524		1788
Flt Permitted		1.00			1.00	1.00		0.19	1.00	1.00		0.22
Satd. Flow (perm)		3435			3539	1615		348	4988	1524		411
Peak-hour factor, PHF	0.99	0.99	0.99	0.84	0.84	0.84	0.91	0.91	0.91	0.91	0.98	0.98
Adj. Flow (vph)	0	245	91	0	375	186	30	78	1089	162	11	153
RTOR Reduction (vph)	0	0	0	0	0	0	0	0	0	61	0	0
Lane Group Flow (vph)	0	336	0	0	375	186	0	108	1089	101	0	164
Heavy Vehicles (%)	0%	0%	3%	0%	2%	0%	4%	0%	4%	6%	0%	1%
Turn Type		NA			NA	Perm	pm+pt	pm+pt	NA	Perm	pm+pt	pm+pt
Protected Phases		4			8		5	5	2		1	1
Permitted Phases						8	2	2		2	6	6
Actuated Green, G (s)		25.4			25.4	25.4		103.0	93.8	93.8		106.2
Effective Green, g (s)		25.4			25.4	25.4		103.0	93.8	93.8		106.2
Actuated g/C Ratio		0.17			0.17	0.17		0.69	0.63	0.63		0.71
Clearance Time (s)		7.5			7.5	7.5		7.0	5.5	5.5		7.0
Vehicle Extension (s)		4.0			4.0	4.0		4.0	0.2	0.2		4.0
Lane Grp Cap (vph)		581			599	273		327	3119	953		390
v/s Ratio Prot		0.10			0.11			0.02	0.22			c0.03
v/s Ratio Perm						c0.12		0.21		0.07		c0.27
v/c Ratio		0.58			0.63	0.68		0.33	0.35	0.11		0.42
Uniform Delay, d1		57.4			57.9	58.5		8.4	13.5	11.3		7.8
Progression Factor		1.00			1.00	1.00		1.00	1.00	1.00		1.00
Incremental Delay, d2		1.7			2.3	7.4		0.8	0.3	0.2		1.0
Delay (s)		59.0			60.2	65.9		9.3	13.8	11.5		8.8
Level of Service		E			E	E		A	B	B		A
Approach Delay (s)		59.0			62.1				13.1			
Approach LOS		E			E				B			
Intersection Summary												
HCM 2000 Control Delay			24.8				HCM 2000 Level of Service		C			
HCM 2000 Volume to Capacity ratio			0.48									
Actuated Cycle Length (s)			150.0				Sum of lost time (s)		20.0			
Intersection Capacity Utilization			55.6%				ICU Level of Service		B			
Analysis Period (min)			15									
c Critical Lane Group												

HCM Signalized Intersection Capacity Analysis
 5: Rockville Pike & Twinbrook Pkwy



Movement	SBT	SBR
Lane Configurations	↑↑↑	↘
Traffic Volume (vph)	1161	65
Future Volume (vph)	1161	65
Ideal Flow (vphpl)	1900	1900
Total Lost time (s)	5.5	
Lane Util. Factor	0.91	
Frt	0.99	
Flt Protected	1.00	
Satd. Flow (prot)	5004	
Flt Permitted	1.00	
Satd. Flow (perm)	5004	
Peak-hour factor, PHF	0.98	0.98
Adj. Flow (vph)	1185	66
RTOR Reduction (vph)	3	0
Lane Group Flow (vph)	1248	0
Heavy Vehicles (%)	3%	0%
Turn Type	NA	
Protected Phases	6	
Permitted Phases		
Actuated Green, G (s)	95.4	
Effective Green, g (s)	95.4	
Actuated g/C Ratio	0.64	
Clearance Time (s)	5.5	
Vehicle Extension (s)	0.2	
Lane Grp Cap (vph)	3182	
v/s Ratio Prot	0.25	
v/s Ratio Perm		
v/c Ratio	0.39	
Uniform Delay, d1	13.2	
Progression Factor	1.00	
Incremental Delay, d2	0.4	
Delay (s)	13.6	
Level of Service	B	
Approach Delay (s)	13.0	
Approach LOS	B	

Intersection Summary

Intersection	
Intersection Delay, s/veh	7.6
Intersection LOS	A

Movement	EBL	EBT	EBR	WBL	WBT	WBR	NBL	NBT	NBR	SBL	SBT	SBR
Lane Configurations		↕			↕			↕			↕	
Traffic Vol, veh/h	12	12	0	6	30	9	0	13	7	19	13	65
Future Vol, veh/h	12	12	0	6	30	9	0	13	7	19	13	65
Peak Hour Factor	0.67	0.67	0.67	0.87	0.87	0.87	0.71	0.71	0.71	0.87	0.87	0.87
Heavy Vehicles, %	0	0	0	0	0	0	0	0	0	26	8	3
Mvmt Flow	18	18	0	7	34	10	0	18	10	22	15	75
Number of Lanes	0	1	0	0	1	0	0	1	0	0	1	0

Approach	EB	WB	NB	SB
Opposing Approach	WB	EB	SB	NB
Opposing Lanes	1	1	1	1
Conflicting Approach Left	SB	NB	EB	WB
Conflicting Lanes Left	1	1	1	1
Conflicting Approach Right	NB	SB	WB	EB
Conflicting Lanes Right	1	1	1	1
HCM Control Delay	7.6	7.4	7.1	7.8
HCM LOS	A	A	A	A

Lane	NBLn1	EBLn1	WBLn1	SBLn1
Vol Left, %	0%	50%	13%	20%
Vol Thru, %	65%	50%	67%	13%
Vol Right, %	35%	0%	20%	67%
Sign Control	Stop	Stop	Stop	Stop
Traffic Vol by Lane	20	24	45	97
LT Vol	0	12	6	19
Through Vol	13	12	30	13
RT Vol	7	0	9	65
Lane Flow Rate	28	36	52	111
Geometry Grp	1	1	1	1
Degree of Util (X)	0.031	0.043	0.059	0.129
Departure Headway (Hd)	3.927	4.282	4.076	4.153
Convergence, Y/N	Yes	Yes	Yes	Yes
Cap	900	825	867	857
Service Time	2.001	2.365	2.156	2.205
HCM Lane V/C Ratio	0.031	0.044	0.06	0.13
HCM Control Delay	7.1	7.6	7.4	7.8
HCM Lane LOS	A	A	A	A
HCM 95th-tile Q	0.1	0.1	0.2	0.4

Intersection												
Int Delay, s/veh	6.7											
Movement	EBL	EBT	EBR	WBL	WBT	WBR	NBL	NBT	NBR	SBL	SBT	SBR
Lane Configurations		+			+			+			+	
Traffic Vol, veh/h	0	0	0	79	0	4	0	7	10	2	5	0
Future Vol, veh/h	0	0	0	79	0	4	0	7	10	2	5	0
Conflicting Peds, #/hr	0	0	0	0	0	0	0	0	0	0	0	0
Sign Control	Stop	Stop	Stop	Stop	Stop	Stop	Free	Free	Free	Free	Free	Free
RT Channelized	-	-	None	-	-	None	-	-	None	-	-	None
Storage Length	-	-	-	-	-	-	-	-	-	-	-	-
Veh in Median Storage, #	-	0	-	-	0	-	-	0	-	-	0	-
Grade, %	-	0	-	-	0	-	-	0	-	-	0	-
Peak Hour Factor	92	92	92	94	94	94	71	71	71	58	58	58
Heavy Vehicles, %	0	0	0	3	0	0	0	0	0	0	0	0
Mvmt Flow	0	0	0	84	0	4	0	10	14	3	9	0

Major/Minor	Minor2		Minor1		Major1			Major2				
Conflicting Flow All	34	39	9	32	32	17	9	0	0	24	0	0
Stage 1	15	15	-	17	17	-	-	-	-	-	-	-
Stage 2	19	24	-	15	15	-	-	-	-	-	-	-
Critical Hdwy	7.1	6.5	6.2	7.13	6.5	6.2	4.1	-	-	4.1	-	-
Critical Hdwy Stg 1	6.1	5.5	-	6.13	5.5	-	-	-	-	-	-	-
Critical Hdwy Stg 2	6.1	5.5	-	6.13	5.5	-	-	-	-	-	-	-
Follow-up Hdwy	3.5	4	3.3	3.527	4	3.3	2.2	-	-	2.2	-	-
Pot Cap-1 Maneuver	978	857	1079	973	865	1068	1624	-	-	1604	-	-
Stage 1	1010	887	-	1000	885	-	-	-	-	-	-	-
Stage 2	1005	879	-	1002	887	-	-	-	-	-	-	-
Platoon blocked, %								-	-	-	-	-
Mov Cap-1 Maneuver	972	855	1079	971	863	1068	1624	-	-	1604	-	-
Mov Cap-2 Maneuver	972	855	-	971	863	-	-	-	-	-	-	-
Stage 1	1010	885	-	1000	885	-	-	-	-	-	-	-
Stage 2	1001	879	-	1000	885	-	-	-	-	-	-	-

Approach	EB	WB	NB	SB
HCM Control Delay, s	0	9.1	0	2.1
HCM LOS	A	A		

Minor Lane/Major Mvmt	NBL	NBT	NBR	EBLn1WBLn1	SBL	SBT	SBR
Capacity (veh/h)	1624	-	-	-	975	1604	-
HCM Lane V/C Ratio	-	-	-	-	0.091	0.002	-
HCM Control Delay (s)	0	-	-	0	9.1	7.2	0
HCM Lane LOS	A	-	-	A	A	A	A
HCM 95th %tile Q(veh)	0	-	-	-	0.3	0	-

Intersection												
Int Delay, s/veh	1.8											
Movement	EBL	EBT	EBR	WBL	WBT	WBR	NBL	NBT	NBR	SBL	SBT	SBR
Lane Configurations		↑↑			↑↑		↑		↑	↑		↑
Traffic Vol, veh/h	0	285	31	143	304	0	20	0	55	0	0	1
Future Vol, veh/h	0	285	31	143	304	0	20	0	55	0	0	1
Conflicting Peds, #/hr	0	0	0	0	0	0	0	0	0	0	0	0
Sign Control	Free	Free	Free	Free	Free	Free	Yield	Yield	Yield	Stop	Stop	Stop
RT Channelized	-	-	None	-	-	None	-	-	None	-	-	None
Storage Length	-	-	-	-	-	-	0	-	0	0	-	0
Veh in Median Storage, #	-	0	-	-	0	-	1081192448	-	-	0	-	-
Grade, %	-	0	-	-	0	-	-	0	-	-	0	-
Peak Hour Factor	93	93	93	86	86	86	75	75	75	92	92	92
Heavy Vehicles, %	0	2	0	0	2	0	0	0	0	0	0	0
Mvmt Flow	0	306	33	166	353	0	27	0	73	0	0	1

Major/Minor	Major1			Major2			Minor2				
Conflicting Flow All	-	0	0	339	0	0			838	-	177
Stage 1	-	-	-	-	-	-			685	-	-
Stage 2	-	-	-	-	-	-			153	-	-
Critical Hdwy	-	-	-	4.1	-	-			6.8	-	6.9
Critical Hdwy Stg 1	-	-	-	-	-	-			5.8	-	-
Critical Hdwy Stg 2	-	-	-	-	-	-			5.8	-	-
Follow-up Hdwy	-	-	-	2.2	-	-			3.5	-	3.3
Pot Cap-1 Maneuver	0	-	-	1231	-	0			309	0	842
Stage 1	0	-	-	-	-	0			467	0	-
Stage 2	0	-	-	-	-	0			865	0	-
Platoon blocked, %	-	-	-	-	-	-			-	-	-
Mov Cap-1 Maneuver	-	-	-	1231	-	-			257	0	842
Mov Cap-2 Maneuver	-	-	-	-	-	-			257	0	-
Stage 1	-	-	-	-	-	-			467	0	-
Stage 2	-	-	-	-	-	-			720	0	-

Approach	EB	WB	SB
HCM Control Delay, s	0	3	9.3
HCM LOS			A

Minor Lane/Major Mvmt	EBT	EBR	WBL	WBT	SBLn1	SBLn2
Capacity (veh/h)	-	-	1231	-	-	842
HCM Lane V/C Ratio	-	-	0.135	-	-	0.001
HCM Control Delay (s)	-	-	8.4	0.4	0	9.3
HCM Lane LOS	-	-	A	A	A	A
HCM 95th %tile Q(veh)	-	-	0.5	-	-	0

Queues
3: East Jefferson St & Rollins Ave

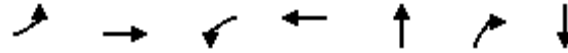

Lane Group	EBL	EBT	WBL	WBT	NBT	NBR	SBT
Lane Group Flow (vph)	11	92	452	131	501	447	485
v/c Ratio	0.09	0.53	0.89	0.27	0.58	0.34	0.33
Control Delay	37.1	40.3	51.8	15.1	24.0	4.0	18.1
Queue Delay	0.0	0.0	0.0	0.0	0.0	0.0	0.0
Total Delay	37.1	40.3	51.8	15.1	24.0	4.0	18.1
Queue Length 50th (ft)	6	39	240	31	216	59	93
Queue Length 95th (ft)	15	52	#374	72	#372	119	150
Internal Link Dist (ft)		1000		777	823		684
Turn Bay Length (ft)			250				
Base Capacity (vph)	175	250	585	547	867	1304	1486
Starvation Cap Reductn	0	0	0	0	0	0	0
Spillback Cap Reductn	0	0	0	0	0	0	0
Storage Cap Reductn	0	0	0	0	0	0	0
Reduced v/c Ratio	0.06	0.37	0.77	0.24	0.58	0.34	0.33

Intersection Summary

95th percentile volume exceeds capacity, queue may be longer.
Queue shown is maximum after two cycles.

HCM Signalized Intersection Capacity Analysis
3: East Jefferson St & Rollins Ave

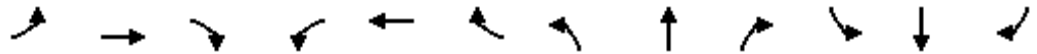

Movement	EBL	EBT	EBR	WBL	WBT	WBR	NBL	NBT	NBR	SBL	SBT	SBR
Lane Configurations												
Traffic Volume (vph)	7	39	19	425	63	60	2	479	429	29	388	14
Future Volume (vph)	7	39	19	425	63	60	2	479	429	29	388	14
Ideal Flow (vphpl)	1900	1900	1900	1900	1900	1900	1900	1900	1900	1900	1900	1900
Total Lost time (s)	5.5	5.5		5.0	5.0			6.0	6.0		6.0	
Lane Util. Factor	1.00	1.00		1.00	1.00			1.00	1.00		0.95	
Frt	1.00	0.95		1.00	0.93			1.00	0.85		1.00	
Flt Protected	0.95	1.00		0.95	1.00			1.00	1.00		1.00	
Satd. Flow (prot)	1262	1666		1805	1569			1863	1599		3548	
Flt Permitted	0.95	1.00		0.95	1.00			1.00	1.00		0.89	
Satd. Flow (perm)	1262	1666		1805	1569			1860	1599		3185	
Peak-hour factor, PHF	0.63	0.63	0.63	0.94	0.94	0.94	0.96	0.96	0.96	0.89	0.89	0.89
Adj. Flow (vph)	11	62	30	452	67	64	2	499	447	33	436	16
RTOR Reduction (vph)	0	20	0	0	41	0	0	0	0	0	2	0
Lane Group Flow (vph)	11	72	0	452	90	0	0	501	447	0	483	0
Heavy Vehicles (%)	43%	0%	26%	0%	0%	2%	0%	2%	1%	0%	1%	0%
Parking (#/hr)					0							
Turn Type	Split	NA		Split	NA		Perm	NA	pt+ov	Perm	NA	
Protected Phases	4	4		3	3			2	2 3			6
Permitted Phases							2				6	
Actuated Green, G (s)	7.4	7.4		25.3	25.3			40.8	72.1		40.8	
Effective Green, g (s)	7.4	7.4		25.3	25.3			40.8	72.1		40.8	
Actuated g/C Ratio	0.08	0.08		0.28	0.28			0.45	0.80		0.45	
Clearance Time (s)	5.5	5.5		5.0	5.0			6.0			6.0	
Vehicle Extension (s)	2.0	2.0		1.0	1.0			5.0			5.0	
Lane Grp Cap (vph)	103	136		507	441			843	1280		1443	
v/s Ratio Prot	0.01	c0.04		c0.25	0.06				0.28			
v/s Ratio Perm								c0.27			0.15	
v/c Ratio	0.11	0.53		0.89	0.20			0.59	0.35		0.33	
Uniform Delay, d1	38.2	39.6		31.0	24.7			18.4	2.5		15.9	
Progression Factor	1.00	1.00		1.00	1.00			1.00	1.00		1.00	
Incremental Delay, d2	0.2	1.7		17.3	0.1			3.1	0.1		0.6	
Delay (s)	38.4	41.3		48.3	24.8			21.5	2.5		16.5	
Level of Service	D	D		D	C			C	A		B	
Approach Delay (s)		41.0			43.0			12.5			16.5	
Approach LOS		D			D			B			B	

Intersection Summary			
HCM 2000 Control Delay	23.2	HCM 2000 Level of Service	C
HCM 2000 Volume to Capacity ratio	0.69		
Actuated Cycle Length (s)	90.0	Sum of lost time (s)	16.5
Intersection Capacity Utilization	72.6%	ICU Level of Service	C
Analysis Period (min)	15		

c Critical Lane Group

Queues
5: Rockville Pike & Twinbrook Pkwy



Lane Group	EBT	WBT	WBR	NBL	NBT	NBR	SBL	SBT
Lane Group Flow (vph)	592	540	229	118	1565	238	279	1493
v/c Ratio	0.78	0.69	0.66	0.46	0.60	0.27	0.81	0.50
Control Delay	63.2	58.9	63.2	16.8	28.0	12.3	50.1	20.0
Queue Delay	0.0	0.0	0.0	0.0	0.0	0.0	0.0	0.0
Total Delay	63.2	58.9	63.2	16.8	28.0	12.3	50.1	20.0
Queue Length 50th (ft)	288	257	206	36	405	65	170	303
Queue Length 95th (ft)	349	314	294	64	473	129	#307	394
Internal Link Dist (ft)	203	744			712			906
Turn Bay Length (ft)			100	150		290	350	
Base Capacity (vph)	851	878	389	405	2618	880	365	2968
Starvation Cap Reductn	0	0	0	0	0	0	0	0
Spillback Cap Reductn	0	0	0	0	0	0	0	0
Storage Cap Reductn	0	0	0	0	0	0	0	0
Reduced v/c Ratio	0.70	0.62	0.59	0.29	0.60	0.27	0.76	0.50

Intersection Summary

95th percentile volume exceeds capacity, queue may be longer.
Queue shown is maximum after two cycles.

HCM Signalized Intersection Capacity Analysis

5: Rockville Pike & Twinbrook Pkwy

City of Rockville Safety Study
Timing Plan: PM Peak



Movement	EBL	EBT	EBR	WBL	WBT	WBR	NBU	NBL	NBT	NBR	SBU	SBL
Lane Configurations		↑↑			↑↑	↑		↔	↑↑↑	↑		↔
Traffic Volume (vph)	0	430	103	0	497	211	26	87	1502	228	5	249
Future Volume (vph)	0	430	103	0	497	211	26	87	1502	228	5	249
Ideal Flow (vphpl)	1900	1900	1900	1900	1900	1900	1900	1900	1900	1900	1900	1900
Total Lost time (s)		7.5			7.5	7.5		7.0	5.5	5.5		7.0
Lane Util. Factor		0.95			0.95	1.00		1.00	0.91	1.00		1.00
Frt		0.97			1.00	0.85		1.00	1.00	0.85		1.00
Flt Protected		1.00			1.00	1.00		0.95	1.00	1.00		0.95
Satd. Flow (prot)		3499			3610	1599		1791	5136	1615		1805
Flt Permitted		1.00			1.00	1.00		0.14	1.00	1.00		0.09
Satd. Flow (perm)		3499			3610	1599		262	5136	1615		164
Peak-hour factor, PHF	0.90	0.90	0.90	0.92	0.92	0.92	0.96	0.96	0.96	0.96	0.91	0.91
Adj. Flow (vph)	0	478	114	0	540	229	27	91	1565	238	5	274
RTOR Reduction (vph)	0	0	0	0	0	0	0	0	0	56	0	0
Lane Group Flow (vph)	0	592	0	0	540	229	0	118	1565	182	0	279
Heavy Vehicles (%)	0%	0%	1%	0%	0%	1%	0%	1%	1%	0%	0%	0%
Turn Type		NA			NA	Perm	pm+pt	pm+pt	NA	Perm	pm+pt	pm+pt
Protected Phases		4			8		5	5	2		1	1
Permitted Phases						8	2	2		2	6	6
Actuated Green, G (s)		32.4			32.4	32.4		87.0	76.5	76.5		104.6
Effective Green, g (s)		32.4			32.4	32.4		87.0	76.5	76.5		104.6
Actuated g/C Ratio		0.22			0.22	0.22		0.58	0.51	0.51		0.70
Clearance Time (s)		7.5			7.5	7.5		7.0	5.5	5.5		7.0
Vehicle Extension (s)		4.0			4.0	4.0		4.0	0.2	0.2		4.0
Lane Grp Cap (vph)		755			779	345		258	2619	823		345
v/s Ratio Prot		c0.17			0.15			0.03	0.30			c0.11
v/s Ratio Perm						0.14		0.23		0.11		c0.45
v/c Ratio		0.78			0.69	0.66		0.46	0.60	0.22		0.81
Uniform Delay, d1		55.5			54.2	53.8		14.9	25.9	20.3		36.6
Progression Factor		1.00			1.00	1.00		1.00	1.00	1.00		1.00
Incremental Delay, d2		5.7			2.9	5.2		1.8	1.0	0.6		13.7
Delay (s)		61.2			57.1	59.0		16.6	26.9	20.9		50.3
Level of Service		E			E	E		B	C	C		D
Approach Delay (s)		61.2			57.7			25.5				
Approach LOS		E			E			C				

Intersection Summary

HCM 2000 Control Delay	34.1	HCM 2000 Level of Service	C
HCM 2000 Volume to Capacity ratio	0.82		
Actuated Cycle Length (s)	150.0	Sum of lost time (s)	20.0
Intersection Capacity Utilization	74.9%	ICU Level of Service	D
Analysis Period (min)	15		
c Critical Lane Group			

HCM Signalized Intersection Capacity Analysis
 5: Rockville Pike & Twinbrook Pkwy



Movement	SBT	SBR
Lane Configurations	↑↑↑	↗
Traffic Volume (vph)	1311	47
Future Volume (vph)	1311	47
Ideal Flow (vphpl)	1900	1900
Total Lost time (s)	5.5	
Lane Util. Factor	0.91	
Frt	0.99	
Flt Protected	1.00	
Satd. Flow (prot)	5107	
Flt Permitted	1.00	
Satd. Flow (perm)	5107	
Peak-hour factor, PHF	0.91	0.91
Adj. Flow (vph)	1441	52
RTOR Reduction (vph)	2	0
Lane Group Flow (vph)	1491	0
Heavy Vehicles (%)	1%	2%
Turn Type	NA	
Protected Phases	6	
Permitted Phases		
Actuated Green, G (s)	87.1	
Effective Green, g (s)	87.1	
Actuated g/C Ratio	0.58	
Clearance Time (s)	5.5	
Vehicle Extension (s)	0.2	
Lane Grp Cap (vph)	2965	
v/s Ratio Prot	0.29	
v/s Ratio Perm		
v/c Ratio	0.50	
Uniform Delay, d1	18.6	
Progression Factor	1.00	
Incremental Delay, d2	0.6	
Delay (s)	19.2	
Level of Service	B	
Approach Delay (s)	24.1	
Approach LOS	C	

Intersection Summary

Intersection	
Intersection Delay, s/veh	8.8
Intersection LOS	A

Movement	EBL	EBT	EBR	WBL	WBT	WBR	NBL	NBT	NBR	SBL	SBT	SBR
Lane Configurations		+			+			+			+	
Traffic Vol, veh/h	17	11	0	21	38	19	1	16	16	39	40	127
Future Vol, veh/h	17	11	0	21	38	19	1	16	16	39	40	127
Peak Hour Factor	0.70	0.70	0.70	0.75	0.75	0.75	0.69	0.69	0.69	0.80	0.80	0.80
Heavy Vehicles, %	0	0	0	0	0	0	0	0	0	21	3	1
Mvmt Flow	24	16	0	28	51	25	1	23	23	49	50	159
Number of Lanes	0	1	0	0	1	0	0	1	0	0	1	0

Approach	EB	WB	NB	SB
Opposing Approach	WB	EB	SB	NB
Opposing Lanes	1	1	1	1
Conflicting Approach Left	SB	NB	EB	WB
Conflicting Lanes Left	1	1	1	1
Conflicting Approach Right	NB	SB	WB	EB
Conflicting Lanes Right	1	1	1	1
HCM Control Delay	8.1	8.3	7.5	9.3
HCM LOS	A	A	A	A

Lane	NBLn1	EBLn1	WBLn1	SBLn1
Vol Left, %	3%	61%	27%	19%
Vol Thru, %	48%	39%	49%	19%
Vol Right, %	48%	0%	24%	62%
Sign Control	Stop	Stop	Stop	Stop
Traffic Vol by Lane	33	28	78	206
LT Vol	1	17	21	39
Through Vol	16	11	38	40
RT Vol	16	0	19	127
Lane Flow Rate	48	40	104	258
Geometry Grp	1	1	1	1
Degree of Util (X)	0.056	0.054	0.131	0.309
Departure Headway (Hd)	4.234	4.833	4.544	4.319
Convergence, Y/N	Yes	Yes	Yes	Yes
Cap	847	742	790	834
Service Time	2.255	2.858	2.565	2.334
HCM Lane V/C Ratio	0.057	0.054	0.132	0.309
HCM Control Delay	7.5	8.1	8.3	9.3
HCM Lane LOS	A	A	A	A
HCM 95th-tile Q	0.2	0.2	0.4	1.3

Intersection												
Int Delay, s/veh	8.2											
Movement	EBL	EBT	EBR	WBL	WBT	WBR	NBL	NBT	NBR	SBL	SBT	SBR
Lane Configurations		+			+			+			+	
Traffic Vol, veh/h	0	0	1	155	1	0	1	7	18	0	3	0
Future Vol, veh/h	0	0	1	155	1	0	1	7	18	0	3	0
Conflicting Peds, #/hr	0	0	0	0	0	0	0	0	0	0	0	0
Sign Control	Stop	Stop	Stop	Stop	Stop	Stop	Free	Free	Free	Free	Free	Free
RT Channelized	-	-	None	-	-	None	-	-	None	-	-	None
Storage Length	-	-	-	-	-	-	-	-	-	-	-	-
Veh in Median Storage, #	-	0	-	-	0	-	-	0	-	-	0	-
Grade, %	-	0	-	-	0	-	-	0	-	-	0	-
Peak Hour Factor	92	92	92	75	75	75	72	72	72	92	92	92
Heavy Vehicles, %	0	0	0	1	0	0	0	0	0	0	0	0
Mvmt Flow	0	0	1	207	1	0	1	10	25	0	3	0

Major/Minor	Minor2		Minor1			Major1			Major2			
Conflicting Flow All	28	40	3	29	28	23	3	0	0	35	0	0
Stage 1	3	3	-	25	25	-	-	-	-	-	-	-
Stage 2	25	37	-	4	3	-	-	-	-	-	-	-
Critical Hdwy	7.1	6.5	6.2	7.11	6.5	6.2	4.1	-	-	4.1	-	-
Critical Hdwy Stg 1	6.1	5.5	-	6.11	5.5	-	-	-	-	-	-	-
Critical Hdwy Stg 2	6.1	5.5	-	6.11	5.5	-	-	-	-	-	-	-
Follow-up Hdwy	3.5	4	3.3	3.509	4	3.3	2.2	-	-	2.2	-	-
Pot Cap-1 Maneuver	987	856	1087	983	869	1060	1632	-	-	1589	-	-
Stage 1	1025	897	-	995	878	-	-	-	-	-	-	-
Stage 2	998	868	-	1021	897	-	-	-	-	-	-	-
Platoon blocked, %								-	-	-	-	-
Mov Cap-1 Maneuver	985	855	1087	981	868	1060	1632	-	-	1589	-	-
Mov Cap-2 Maneuver	985	855	-	981	868	-	-	-	-	-	-	-
Stage 1	1024	897	-	994	877	-	-	-	-	-	-	-
Stage 2	995	867	-	1020	897	-	-	-	-	-	-	-

Approach	EB		WB			NB			SB		
HCM Control Delay, s	8.3		9.7			0.3			0		
HCM LOS	A		A								

Minor Lane/Major Mvmt	NBL	NBT	NBR	EBLn1	WBLn1	SBL	SBT	SBR
Capacity (veh/h)	1632	-	-	1087	980	1589	-	-
HCM Lane V/C Ratio	0.001	-	-	0.001	0.212	-	-	-
HCM Control Delay (s)	7.2	0	-	8.3	9.7	0	-	-
HCM Lane LOS	A	A	-	A	A	A	-	-
HCM 95th %tile Q(veh)	0	-	-	0	0.8	0	-	-

Intersection												
Int Delay, s/veh	1.3											
Movement	EBL	EBT	EBR	WBL	WBT	WBR	NBL	NBT	NBR	SBL	SBT	SBR
Lane Configurations		↑↓			↑↑		↑		↑	↑		↑
Traffic Vol, veh/h	0	457	35	130	510	0	18	0	83	1	0	3
Future Vol, veh/h	0	457	35	130	510	0	18	0	83	1	0	3
Conflicting Peds, #/hr	0	0	0	0	0	0	0	0	0	0	0	0
Sign Control	Free	Free	Free	Free	Free	Free	Yield	Yield	Yield	Stop	Stop	Stop
RT Channelized	-	-	None	-	-	None	-	-	None	-	-	None
Storage Length	-	-	-	-	-	-	0	-	0	0	-	0
Veh in Median Storage, #	-	0	-	-	0	-	1081192448	-	-	0	-	-
Grade, %	-	0	-	-	0	-	-	0	-	-	0	-
Peak Hour Factor	91	91	91	96	96	96	79	79	79	50	50	50
Heavy Vehicles, %	0	1	0	0	1	0	0	0	0	0	0	0
Mvmt Flow	0	502	38	135	531	0	23	0	105	2	0	6

Major/Minor	Major1			Major2			Minor2				
Conflicting Flow All	-	0	0	540	0	0			1052	-	266
Stage 1	-	-	-	-	-	-			801	-	-
Stage 2	-	-	-	-	-	-			251	-	-
Critical Hdwy	-	-	-	4.1	-	-			6.8	-	6.9
Critical Hdwy Stg 1	-	-	-	-	-	-			5.8	-	-
Critical Hdwy Stg 2	-	-	-	-	-	-			5.8	-	-
Follow-up Hdwy	-	-	-	2.2	-	-			3.5	-	3.3
Pot Cap-1 Maneuver	0	-	-	1039	-	0			225	0	738
Stage 1	0	-	-	-	-	0			407	0	-
Stage 2	0	-	-	-	-	0			774	0	-
Platoon blocked, %	-	-	-	-	-	-			-	-	-
Mov Cap-1 Maneuver	-	-	-	1039	-	-			184	0	738
Mov Cap-2 Maneuver	-	-	-	-	-	-			184	0	-
Stage 1	-	-	-	-	-	-			407	0	-
Stage 2	-	-	-	-	-	-			632	0	-

Approach	EB	WB	SB
HCM Control Delay, s	0	2.2	13.6
HCM LOS			B

Minor Lane/Major Mvmt	EBT	EBR	WBL	WBT	SBLn1	SBLn2
Capacity (veh/h)	-	-	1039	-	184	738
HCM Lane V/C Ratio	-	-	0.13	-	0.011	0.008
HCM Control Delay (s)	-	-	9	0.5	24.8	9.9
HCM Lane LOS	-	-	A	A	C	A
HCM 95th %tile Q(veh)	-	-	0.4	-	0	0

APPENDIX D AUTOCAD DESIGNS FOR ALTERNATIVES

CITY OF ROCKVILLE

CONCEPT DESIGN

ROLLINS AVENUE

Option 1: Quick-Build Safety Improvements



KITTELSON & ASSOCIATES
 100 M STREET SE, SUITE 910
 WASHINGTON, DC 20003
 P 202.450.3710

INDEX		
DWG. NO.	SHEET NO.	PLAN TITLE
T-01	1	PROJECT LOCATION & INDEX
T-02	2	GENERAL NOTES & LEGEND
D-01	3	CONSTRUCTION DETAILS
SS-01	4	SIGNING & STRIPING PLAN ALT 1
SS-02	5	SIGNING & STRIPING PLAN ALT 1
SS-03	6	SIGNING & STRIPING PLAN ALT 1
SS-04	7	SIGNING & STRIPING PLAN ALT 1
SS-05	8	SIGNING & STRIPING PLAN ALT 1
SS-06	9	SIGNING & STRIPING PLAN ALT 1
SS-07	10	SIGNING & STRIPING PLAN ALT 1
SS-08	11	SIGN SUMMARY ALT 1
AT-01	12	CONTROL VEHICLE MANEUVER ALT 1
AT-02	13	CONTROL VEHICLE MANEUVER ALT 1
AT-03	14	CONTROL VEHICLE MANEUVER ALT 1
AT-04	15	CONTROL VEHICLE MANEUVER ALT 1
AT-05	16	CONTROL VEHICLE MANEUVER ALT 1
AT-06	17	CONTROL VEHICLE MANEUVER ALT 1
AT-07	18	CONTROL VEHICLE MANEUVER ALT 1
AT-08	19	CONTROL VEHICLE MANEUVER ALT 1
AT-09	20	CONTROL VEHICLE MANEUVER ALT 1
AT-10	21	CONTROL VEHICLE MANEUVER ALT 1
AT-11	22	CONTROL VEHICLE MANEUVER ALT 1

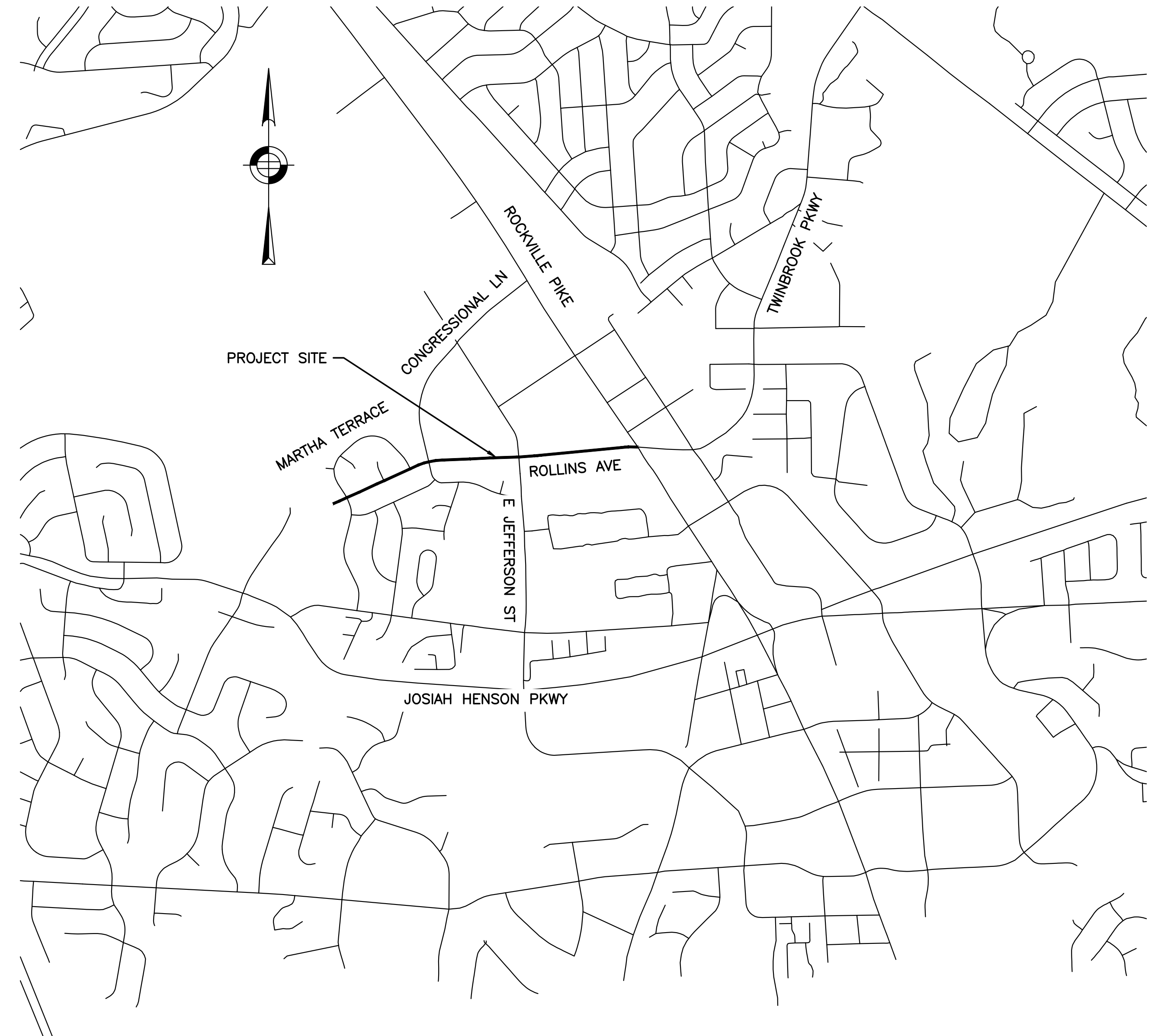

PRELIMINARY
 NOT FOR
 CONSTRUCTION

#	DATE	REVISION	APP'D

Submission Date:
6/30/2026

Drawn: EAA	Designed: EAA	Checked: CKM
---------------	------------------	-----------------

PROJECT NO.
31213.003

ROLLINS AVENUE COMPLETE STREET STUDY
 PROJECT LOCATION & INDEX













SHEET NO.
T-01

Plot Stamp: 6/30/2026 10:33:30 AM - Erika Adams
 File: H:\31\31219 - MCOG TLC and RSP On-Call\003 - Rollins-Twinbrook Complete Street Study\design\CD\31219.003-CD-COVER & NOTES.dwg

ABBREVIATIONS

APRX	APPROXIMATELY
BS	BACK OF SIDEWALK
EXIST	EXISTING
LP	LIGHT POLE/LOW POINT
MNT	MOUNT
PROP	PROPOSED
R	RADIUS
REM	REMOVE
RET	RETAIN
SL	STOP LINE
CW	CROSS WALK

LEGEND

EXISTING	PROPOSED	
		NEW OR RELOCATED SIGN
		SHARED LANE MARKING
		SPEED HUMP MARKING
		CROSSWALK
		FLEX POST
		SIGN POST
		5" SOLID WHITE LINE
		5" SOLID YELLOW LINE
		2x 4" DOUBLE YELLOW CENTER LINES
		5" SOLID WHITE CHANNELIZATION LINES AT 15' O.C.
		5" SOLID YELLOW CHANNELIZATION LINES AT 15' O.C.
		24" MINIMUM WHITE STOP LINE (UNLESS OTHERWISE NOTED)

PRELIMINARY
 NOT FOR
 CONSTRUCTION



KITTELSON & ASSOCIATES
 100 M STREET SE, SUITE 910
 WASHINGTON, DC 20003
 P 202.450.3710

REVISION	DATE	APP'D.

Submission Date:
 6/30/2026

Drawn: EAA	Designed: EAA	Checked: CKM
---------------	------------------	-----------------

PROJECT NO.
 31213.003

ROLINS AVENUE COMPLETE STREET STUDY

GENERAL NOTES & LEGEND

SHEET NO.
 T-02

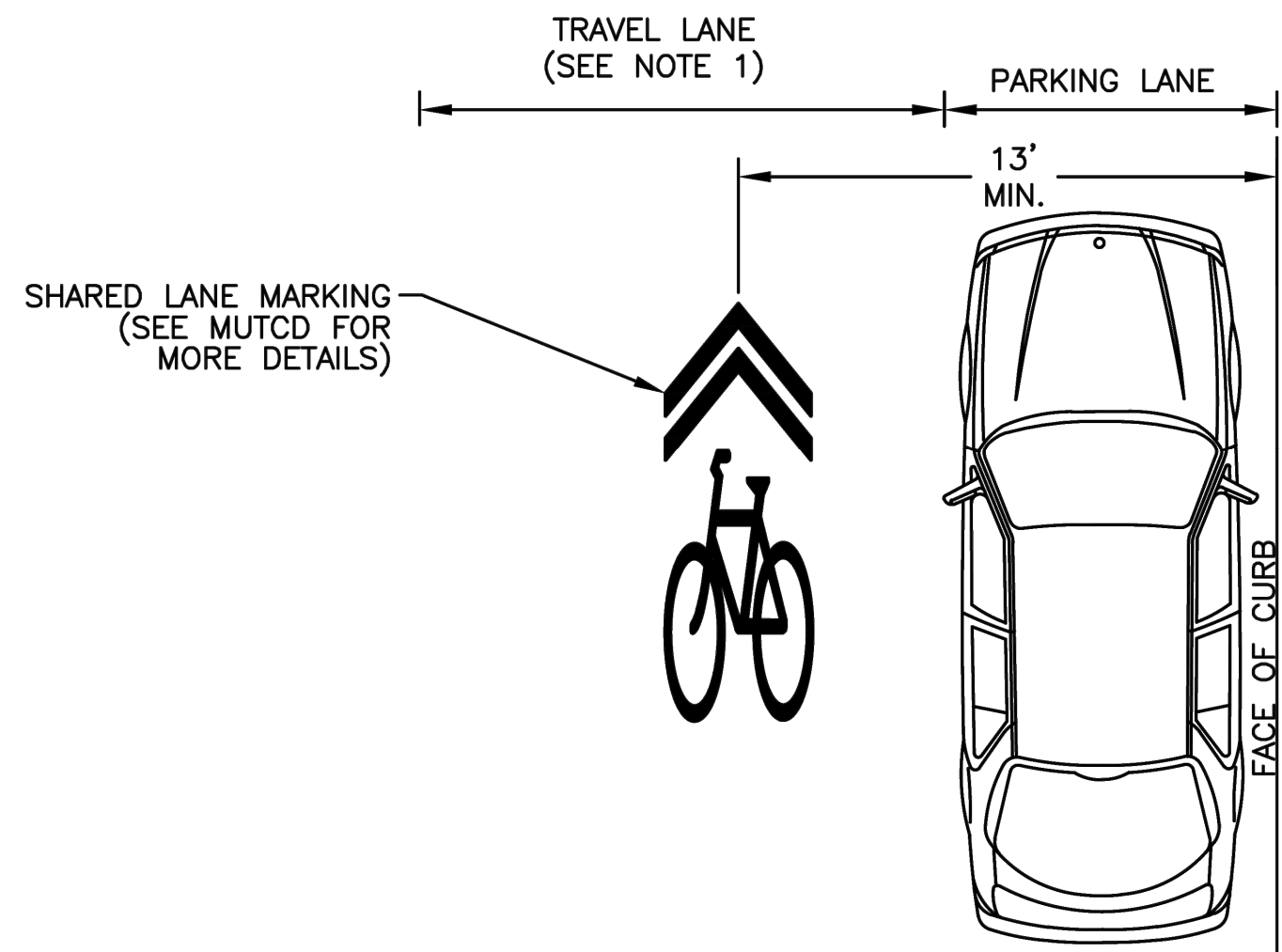

NOTES:

1. IF TRAVEL LANE IS LESS THAN 14' SHARED LANE MARKING SHALL BE CENTERED IN TRAVEL LANE.
2. DESIGN PLANS SHOULD BE CONSULTED FOR VARIATIONS.

TYPICAL SHARED LANE MARKINGS ADJACENT TO ON-STREET PARKING
N.T.S.

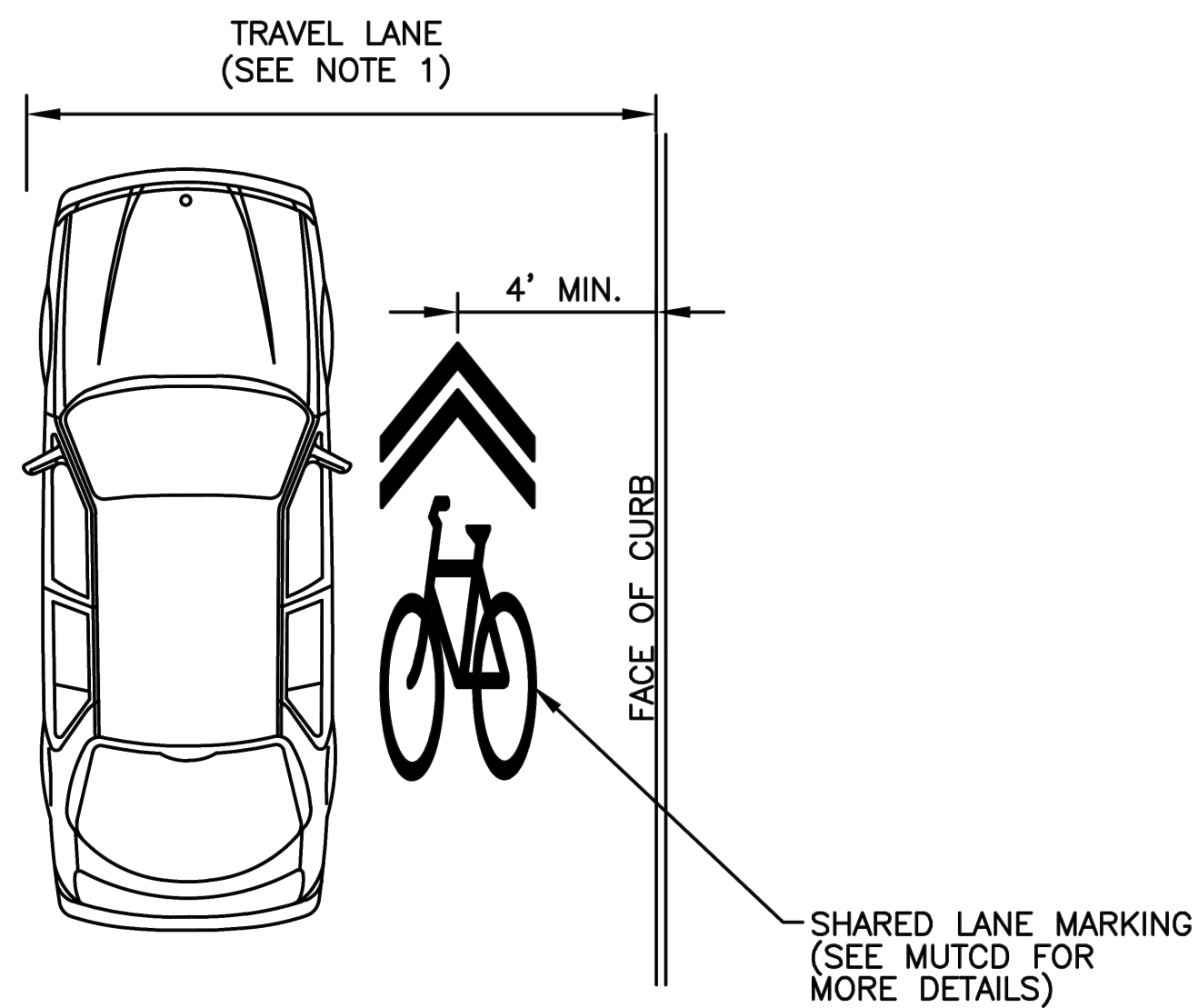

NOTES:

1. IF TRAVEL LANE IS LESS THAN 14' SHARED LANE MARKING SHALL BE CENTERED IN TRAVEL LANE.
2. DESIGN PLANS SHOULD BE CONSULTED FOR VARIATIONS.

TYPICAL SHARED LANE MARKINGS WITHOUT ADJACENT ON-STREET PARKING
N.T.S.

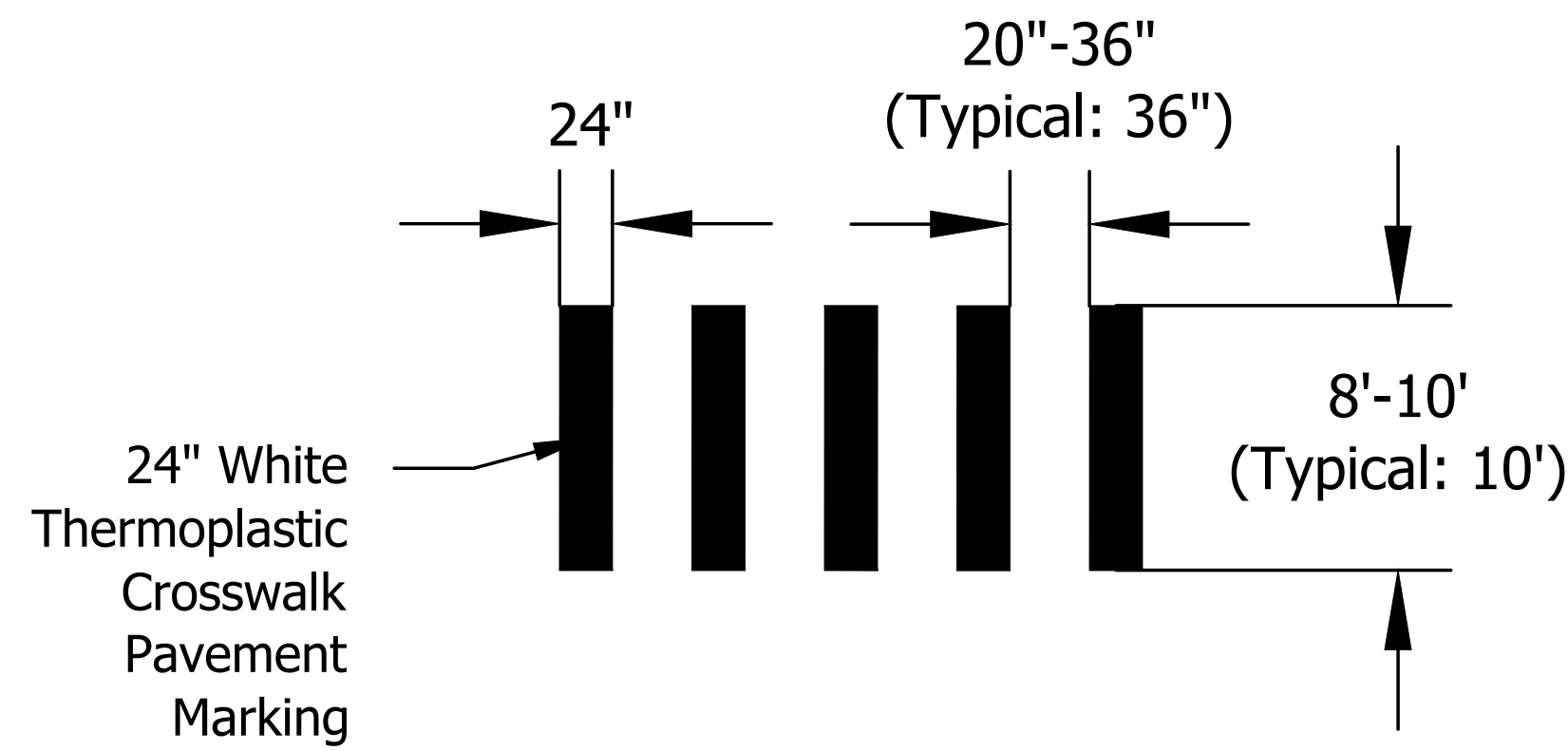

TYPICAL CROSSWALK
N.T.S.

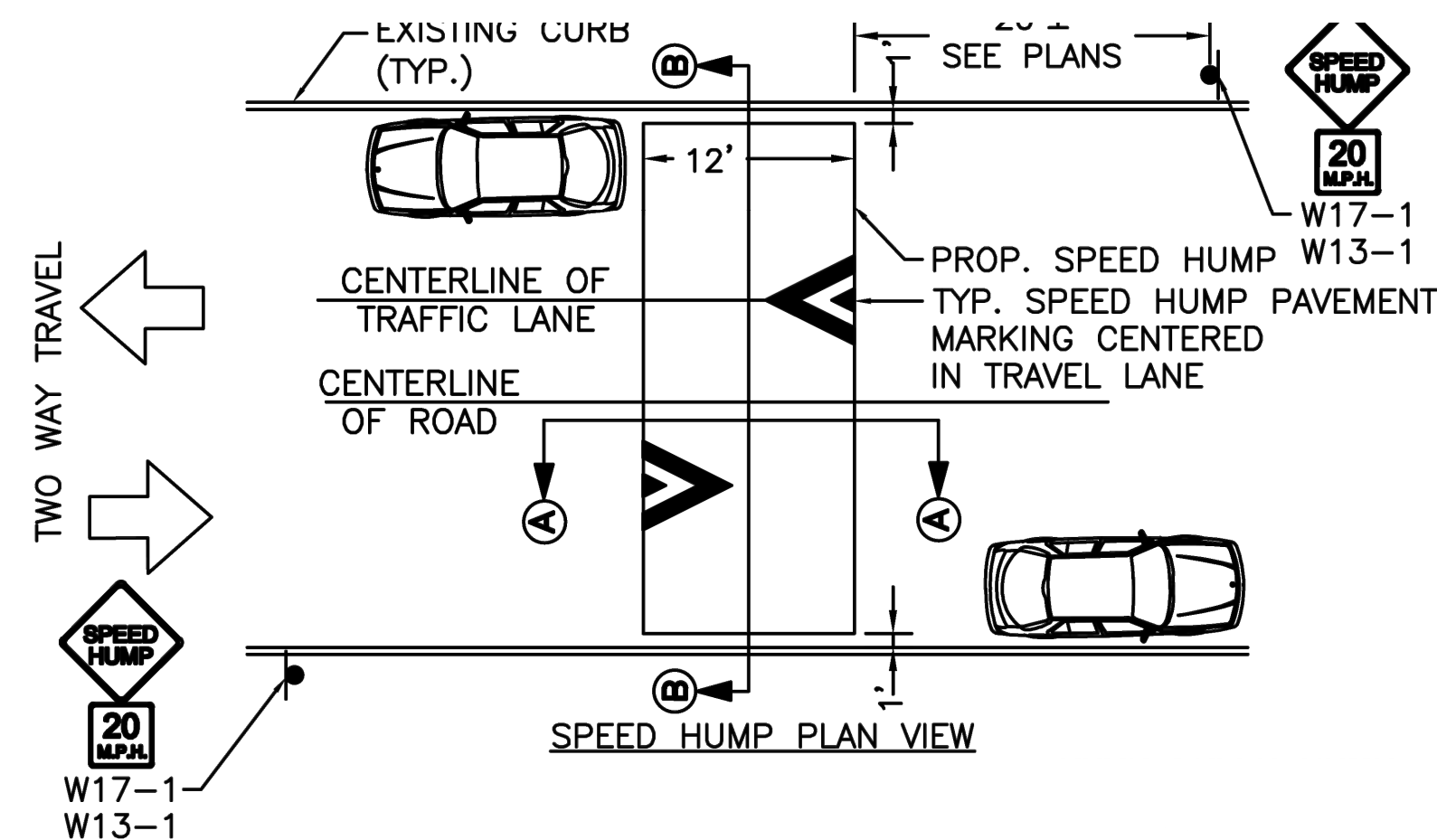

TYPICAL SPEED HUMP
N.T.S.

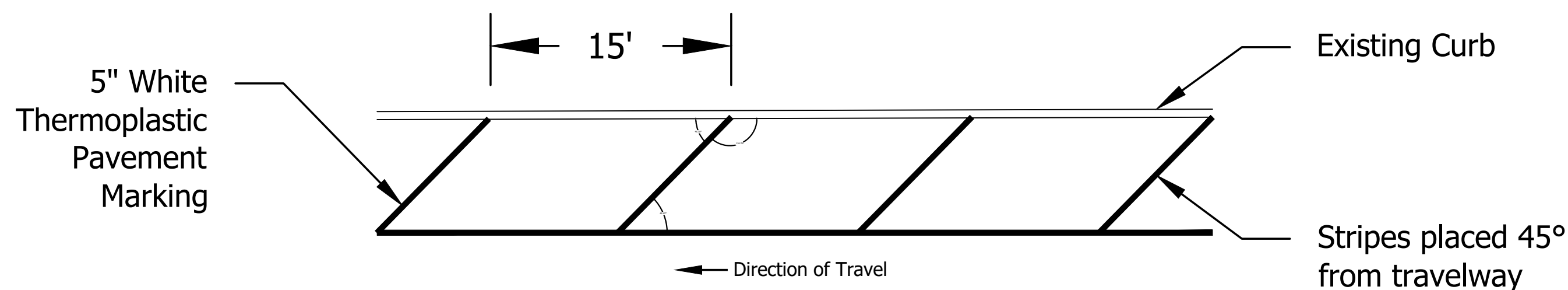

TYPICAL CURB EXTENSION GORE AREA
N.T.S.

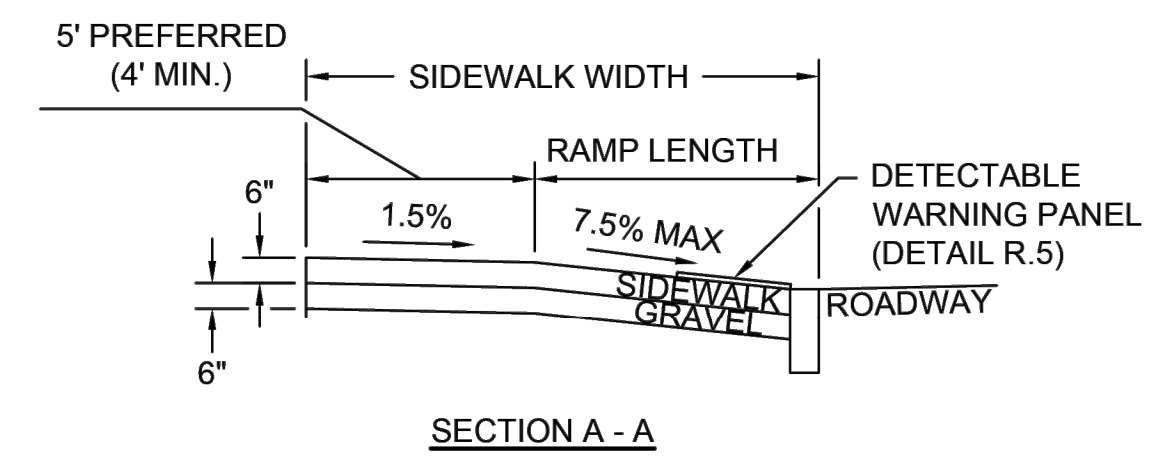
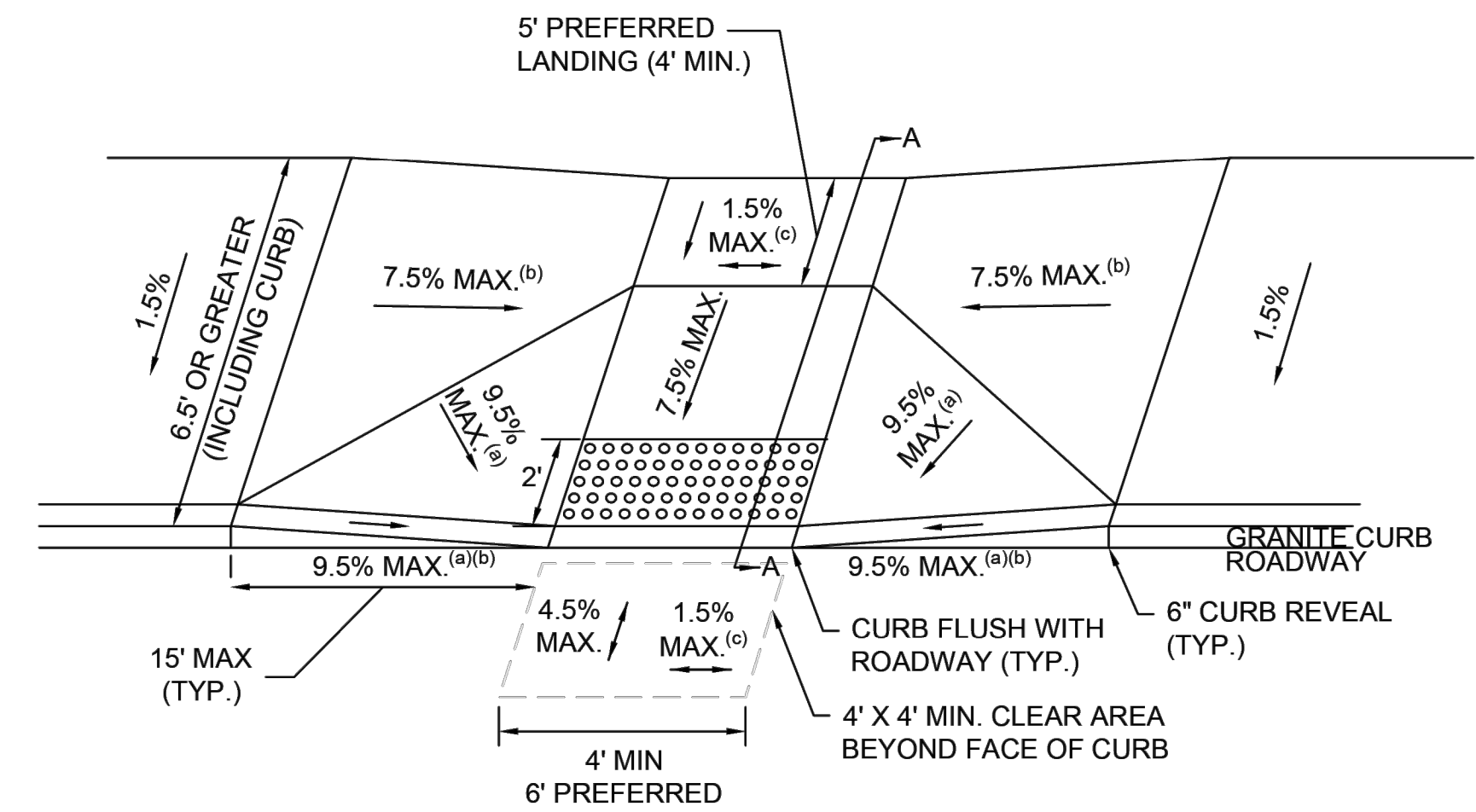

SECTION A - A

NOTES:

1. ^(a) 7.5% PREFERRED SLOPE.
2. ^(b) MAXIMUM SLOPE TRANSITION LENGTH MEASURED ALONG THE FACE OF CURB SHALL BE 15 FEET. A TRANSITION SLOPE GREATER THAN 9.5% IS ONLY ACCEPTABLE WHEN THE TRANSITION STONE REACHES A MAXIMUM LENGTH OF 15 FEET.
3. ^(c) THE LANDING CROSS SLOPE (PARALLEL TO THE CURB LINE) AND THE GUTTER RUNNING SLOPE SHALL BE A MAXIMUM OF 1.5% AT APPROACHES UNDER STOP OR YIELD CONTROL. THE SLOPE MAY EXCEED 1.5% MAXIMUM UNDER THE FOLLOWING CONDITIONS:
 - SIGNAL OR PEDESTRIAN HYBRID BEACON = 4.5% MAX.
 - UNCONTROLLED = 4.5% MAX.
 - MIDDLEBLOCK = NO GREATER THAN STREET GRADE
 - ROUNDABOUT = NO GREATER THAN STREET GRADE
4. ± 0.5% MAX. CONSTRUCTION TOLERANCE PERMITTED ON ALL SLOPES.

PEDESTRIAN RAMP
N.T.S.

Plot Stamp: 6/30/2026 10:33:33 AM - Erika Adams
File: H:\31\31219 - MCOG TLC and RSP On-Call\003 - Rollins-Twinbrook Complete Street Study\design\CD\31219.003-CD-COVER & NOTES.dwg

#	DATE	REVISION	APP'D

Submission Date:
6/30/2026
Drawn: EAA
Designed: EAA
Checked: CKM

PROJECT NO.
31213.003

ROLINS AVENUE COMPLETE STREET STUDY
CONSTRUCTION DETAILS

SHEET NO.
D-01

PRELIMINARY
NOT FOR
CONSTRUCTION

Plot Stamp: 6/30/2026 10:33:45 AM - Erika Adams
 File: H:\31\31219 - MCOG TLC and RSP On-Call\003 - Rollins-Twinbrook Complete Street Study\design_CD\31219.003-CD-SSPLAN-ALT 1.dwg

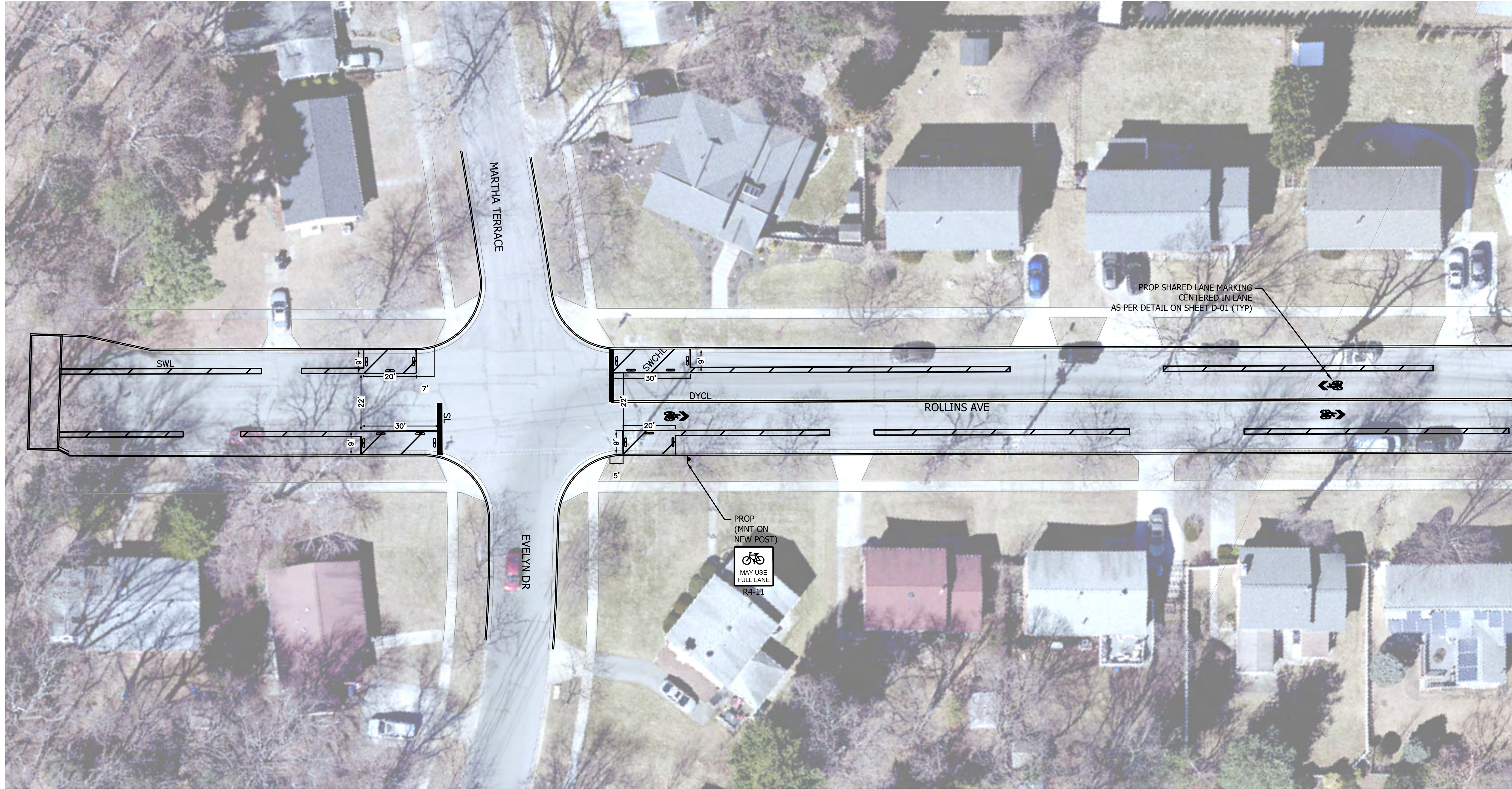

FOR CONTINUATION SEE SHEET SS-02

PRELIMINARY
 NOT FOR
 CONSTRUCTION



KITTELSON & ASSOCIATES
 100 M STREET SE, SUITE 910
 WASHINGTON, DC 20003
 P 202.450.3710

#	DATE	REVISION	APP'D

Submission Date:
 6/30/2026
 Drawn: EAA Designed: EAA Checked: CKM

PROJECT NO.
31213.003

ROLINS AVENUE COMPLETE STREET STUDY

SIGNING & STRIPING PLAN ALT 1

SHEET NO.
SS-01

Plot Stamp: 6/30/2026 10:33:50 AM - Erika Adams
 File: H:\31\31219 - MWCOC TLC and RSP On-Call\003 - Rollins-Twinbrook Complete Street Study\Design_CD\31219.003-CD-SSPLAN-ALT 1.dwg

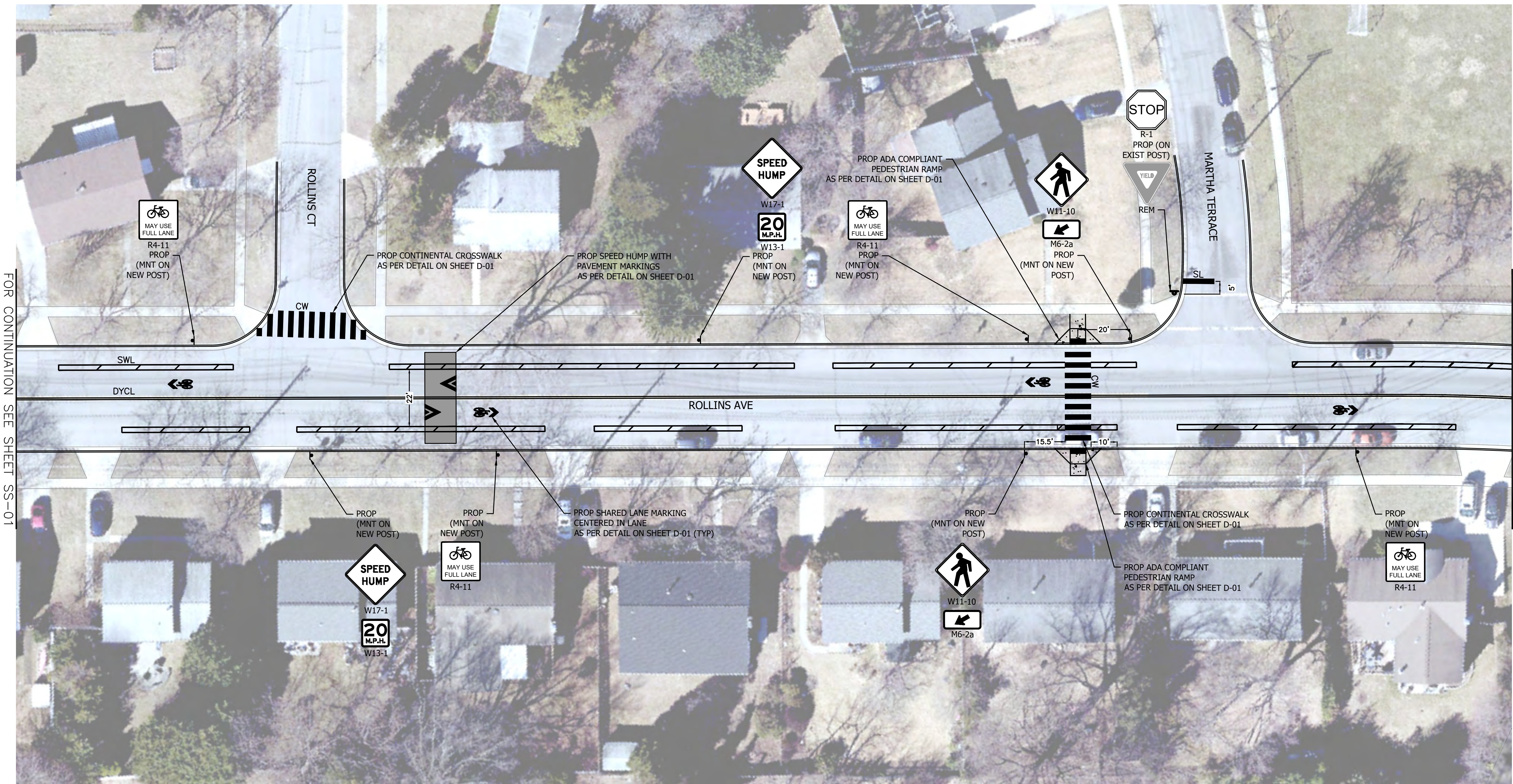

FOR CONTINUATION SEE SHEET SS-01

FOR CONTINUATION SEE SHEET SS-03

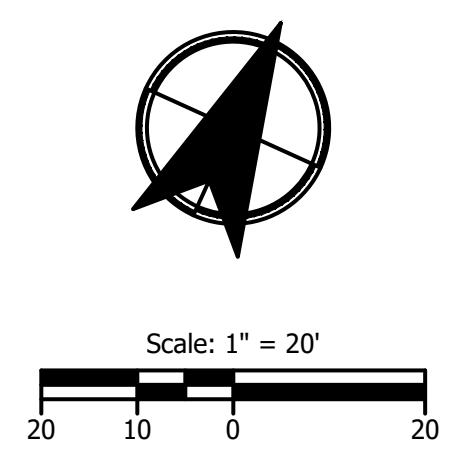

PRELIMINARY
 NOT FOR
 CONSTRUCTION



KITTELSON & ASSOCIATES
 100 M STREET SE, SUITE 910
 WASHINGTON, DC 20003
 P 202.450.3710

#	DATE	REVISION	APP'D

Submission Date: 6/30/2026
 Drawn: EAA Designed: EAA Checked: CKM
 PROJECT NO. 31213.003

ROLINS AVENUE COMPLETE STREET STUDY
 SIGNING & STRIPING PLAN ALT 1

SHEET NO. SS-02

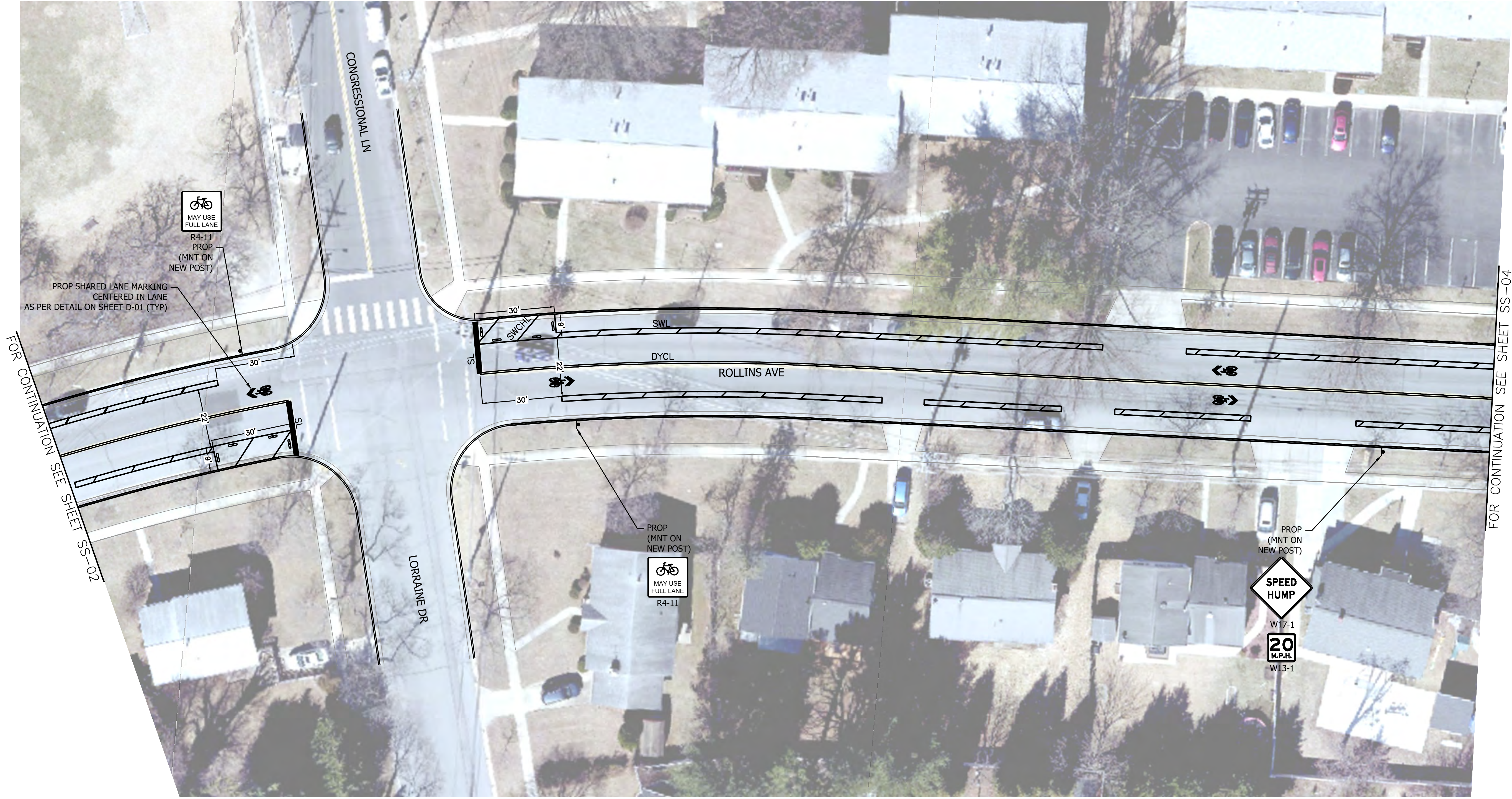

FOR CONTINUATION SEE SHEET SS-02

FOR CONTINUATION SEE SHEET SS-04

PRELIMINARY
 NOT FOR
 CONSTRUCTION

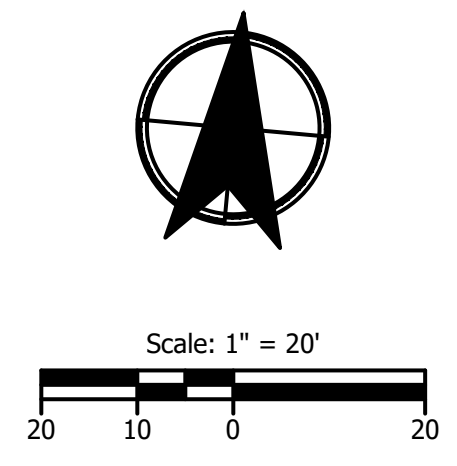

REVISION	DATE	APP'D

Submission Date:
 6/30/2026
 Drawn: EAA Designed: EAA Checked: CKM

PROJECT NO.
 31213.003

**ROLINS AVENUE COMPLETE
 STREET STUDY**
 SIGNING & STRIPING PLAN ALT 1

SHEET NO.
SS-03

FOR CONTINUATION SEE SHEET SS-03



FOR CONTINUATION SEE SHEET SS-05

PRELIMINARY
 NOT FOR
 CONSTRUCTION

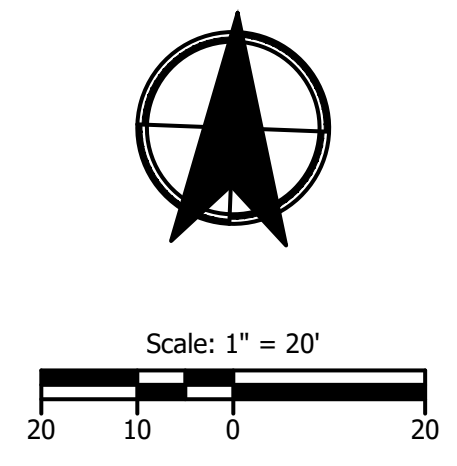

KITTELSON & ASSOCIATES
 100 M STREET SE, SUITE 910
 WASHINGTON, DC 20003
 P 202.450.3710

#	DATE	REVISION	APP'D

Submission Date:
 6/30/2026
 Drawn: EAA Designed: EAA Checked: CKM

PROJECT NO.
 31213.003

ROLLINS AVENUE COMPLETE STREET STUDY
 SIGNING & STRIPING PLAN ALT 1

SHEET NO.
 SS-04

Plot Stamp: 6/30/2026 10:33:57 AM - Erika Adams
 File: H:\31\31219 - MWCOC TLC and RSP On-Call\003 - Rollins-Twinbrook Complete Street Study\design_CD\31219.003-CD-SSPLAN-ALT 1.dwg

FOR CONTINUATION SEE SHEET SS-04

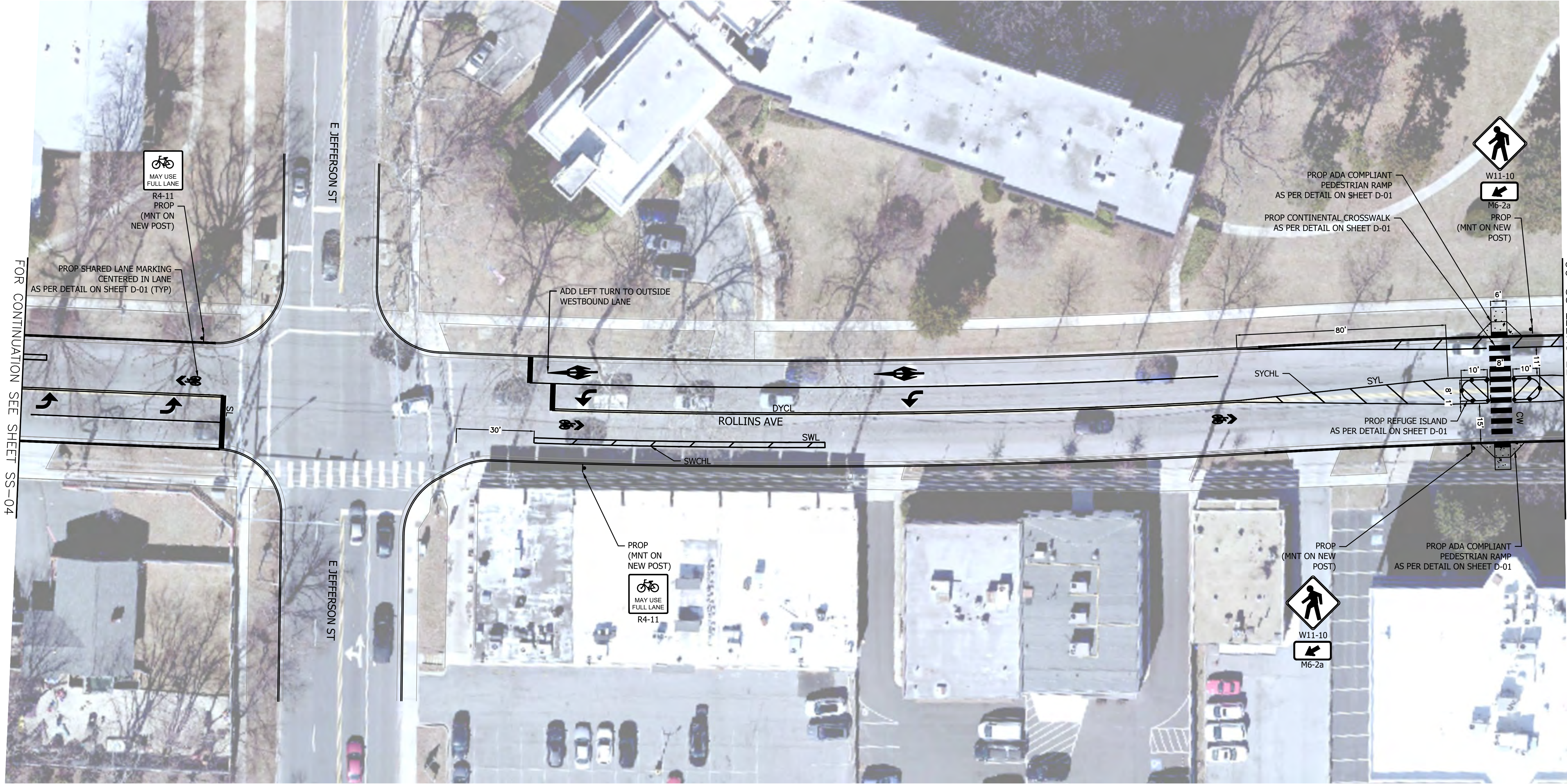

FOR CONTINUATION SEE SHEET SS-06

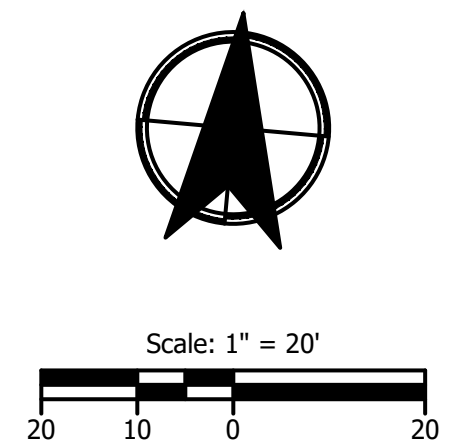

PRELIMINARY
 NOT FOR
 CONSTRUCTION



KITTELSON & ASSOCIATES
 100 M STREET SE, SUITE 910
 WASHINGTON, DC 20003
 P 202.450.3710

#	DATE	REVISION	APP'D

Submission Date: 6/30/2026
 Drawn: EAA Designed: EAA Checked: CKM
 PROJECT NO. 31213.003

ROLINS AVENUE COMPLETE STREET STUDY
 SIGNING & STRIPING PLAN ALT 1

SHEET NO. SS-05

FOR CONTINUATION SEE SHEET SS-05



FOR CONTINUATION SEE SHEET SS-07

PRELIMINARY
 NOT FOR
 CONSTRUCTION



KITTELSON & ASSOCIATES
 100 M STREET SE, SUITE 910
 WASHINGTON, DC 20003
 P 202.450.3710

#	DATE	REVISION	APP'D

Submission Date:
 6/30/2026
 Drawn: EAA Designed: EAA Checked: CKM

PROJECT NO.
31213.003
ROLINS AVENUE COMPLETE STREET STUDY
 SIGNING & STRIPING PLAN ALT 1
 SHEET NO.
SS-06

FOR CONTINUATION SEE SHEET SS-06

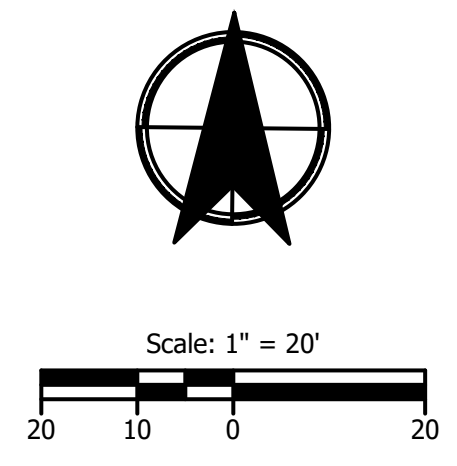
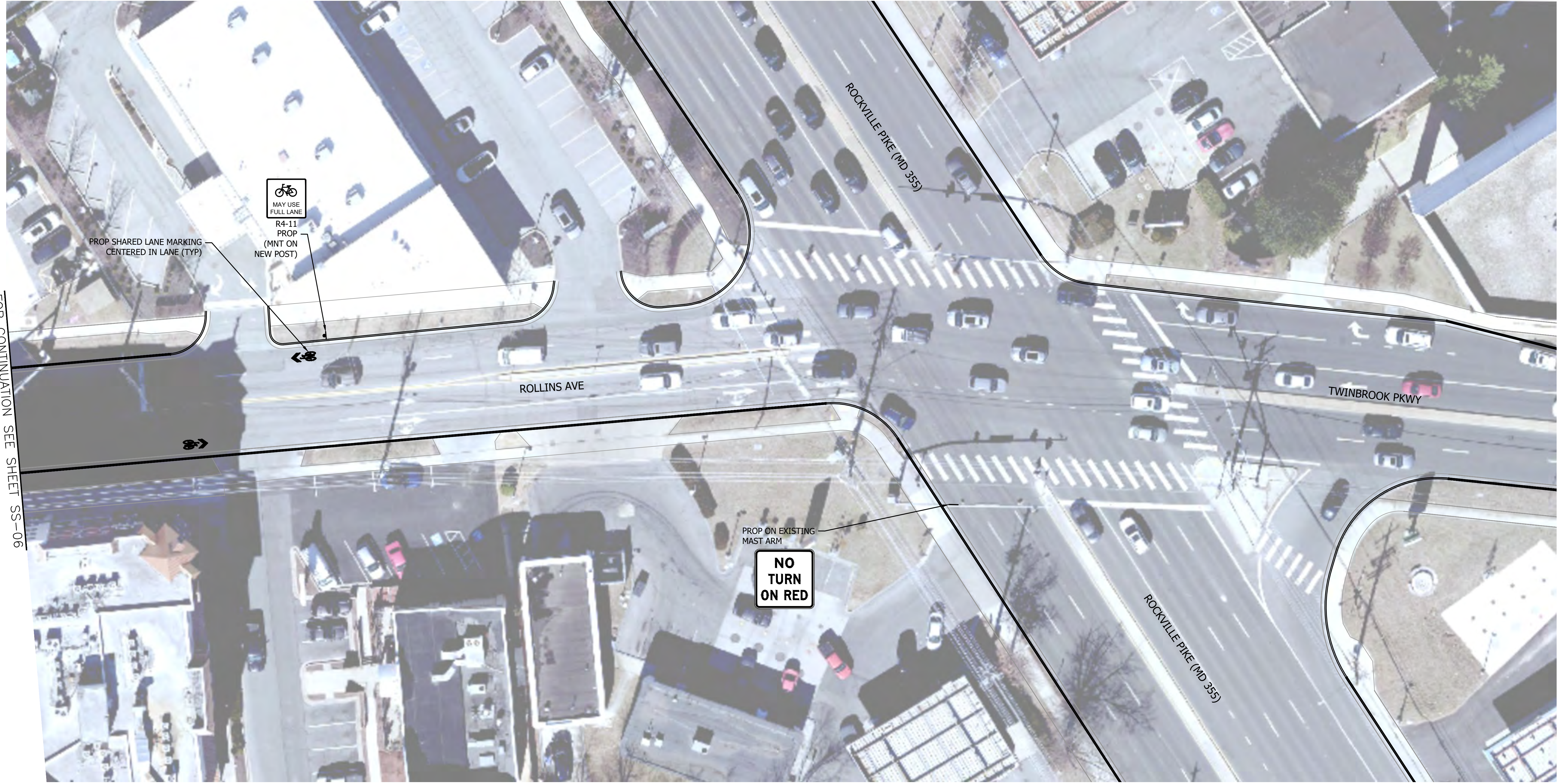

PRELIMINARY
 NOT FOR
 CONSTRUCTION

#	DATE	REVISION	APP'D







Submission Date:
 6/30/2026
 Drawn: EAA Designed: EAA Checked: CKM

PROJECT NO.
31213.003

ROLINS AVENUE COMPLETE STREET STUDY

SIGNING & STRIPING PLAN ALT 1

SHEET NO.
SS-07

IDENTIFICATION NUMBER	SIZE OF SIGN (INCHES)		UNIT AREA SF	TEXT	TEXT DIMENSIONS	NUMBER OF SIGNS REQUIRED	COLOR	POST SIZE AND NUMBER REQUIRED PER SIGN	AREA IN SQUARE FEET
	WIDTH	HEIGHT							
R-1	30"	30"	6.25		SEE MUTCD STANDARD DETAIL	1	SEE MUTCD STANDARD DETAIL	MNT ON EXIST 2" POST	6.25
W11-2	30"	30"	6.25			4		MNT ON 2" POST (2)	25.00
M6-2a	24"	12"	2			4		MNT BENEATH W11-2	8.00
R14-11	30"	30"	6.25	 MAY USE FULL LANE		10		MNT ON 2" POST (10)	62.50
W17-1	30"	30"	6.25			4		MNT ON 2" POST (4)	25.00
W13-1	18"	18"	2.25			4		MNT BENEATH W17-1	9.00
R10-11b	30"	30"	6.25			1		MNT ON EXIST MAST ARM	6.25

PRELIMINARY
 NOT FOR
 CONSTRUCTION



KITTELSON & ASSOCIATES
 100 M STREET SE, SUITE 910
 WASHINGTON, DC 20003
 P 202.450.3710

#	DATE	REVISION	APP'D.

Submission Date:
 6/30/2026
 Drawn: EAA Designed: EAA Checked: CKM

PROJECT NO.
31213.003

ROLINS AVENUE COMPLETE STREET STUDY
 SIGN SUMMARY ALT 1

SHEET NO.
SS-08

Plot Stamp: 6/30/2026 10:34:14 AM - Erika Adams
 File: H:\31\31219 - MCOG TLC and RSP On-Call\003 - Rollins-Twinbrook Complete Street Study\design_CD\31219.003-CD-SSPLAN-ALT 1.dwg

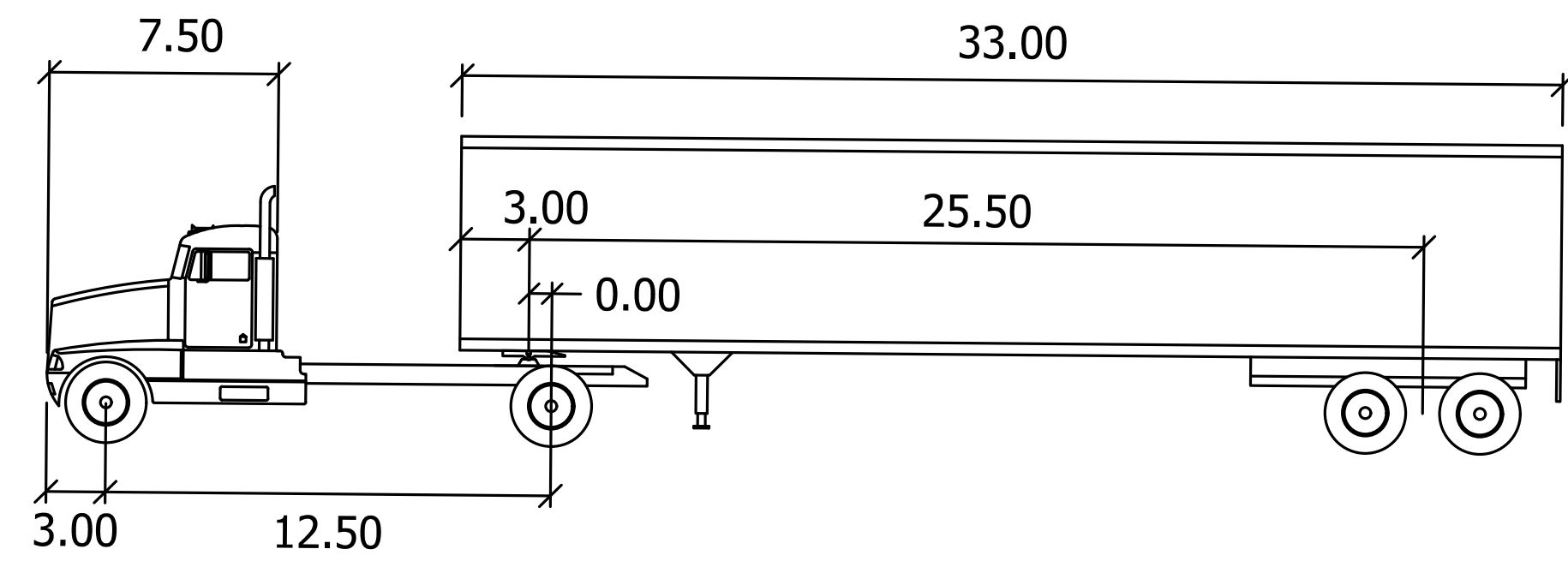
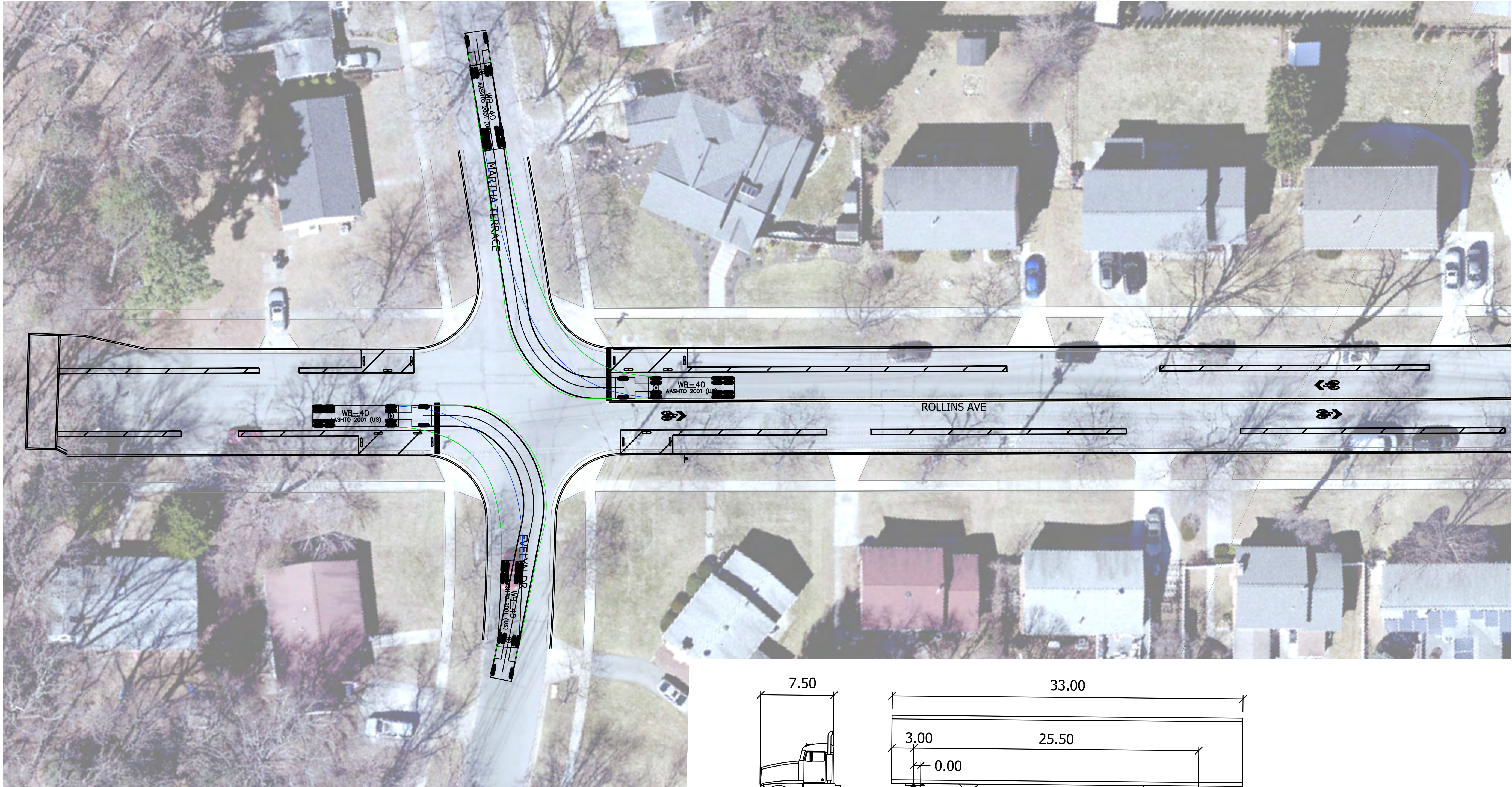

WB-40

	feet		
Tractor Width	: 8.00	Lock to Lock Time	: 6.0
Trailer Width	: 8.00	Steering Angle	: 20.3
Tractor Track	: 8.00	Articulating Angle	: 70.0
Trailer Track	: 8.00		

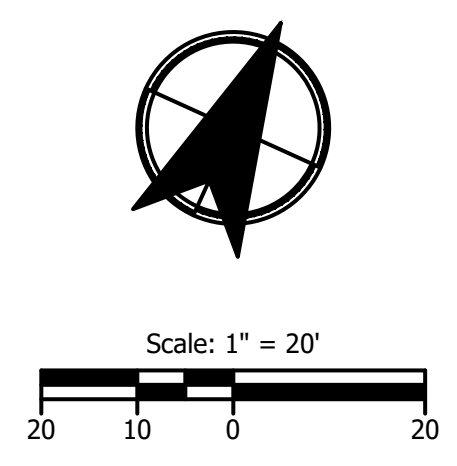

PRELIMINARY
 NOT FOR
 CONSTRUCTION



KITTELSON & ASSOCIATES
 100 M STREET SE, SUITE 910
 WASHINGTON, DC 20003
 P 202.450.3710

#	DATE	REVISION	APP'D.

Submission Date: 6/30/2026
 Drawn: EAA Designed: EAA Checked: CKM
 PROJECT NO. 31213.003

ROLINS AVENUE COMPLETE STREET STUDY
 CONTROL VEHICLE MANEUVER ALT 1
 SHEET NO. AT-01

Plot Stamp: 6/30/2026 10:34:21 AM - Erika Adams
 File: H:\31\31219 - MCOG TLC and RSP On-Call\003 - Rollins-Twinbrook Complete Street Study\design_CD\31219.003-CD-SSPLAN-ALT 1.dwg

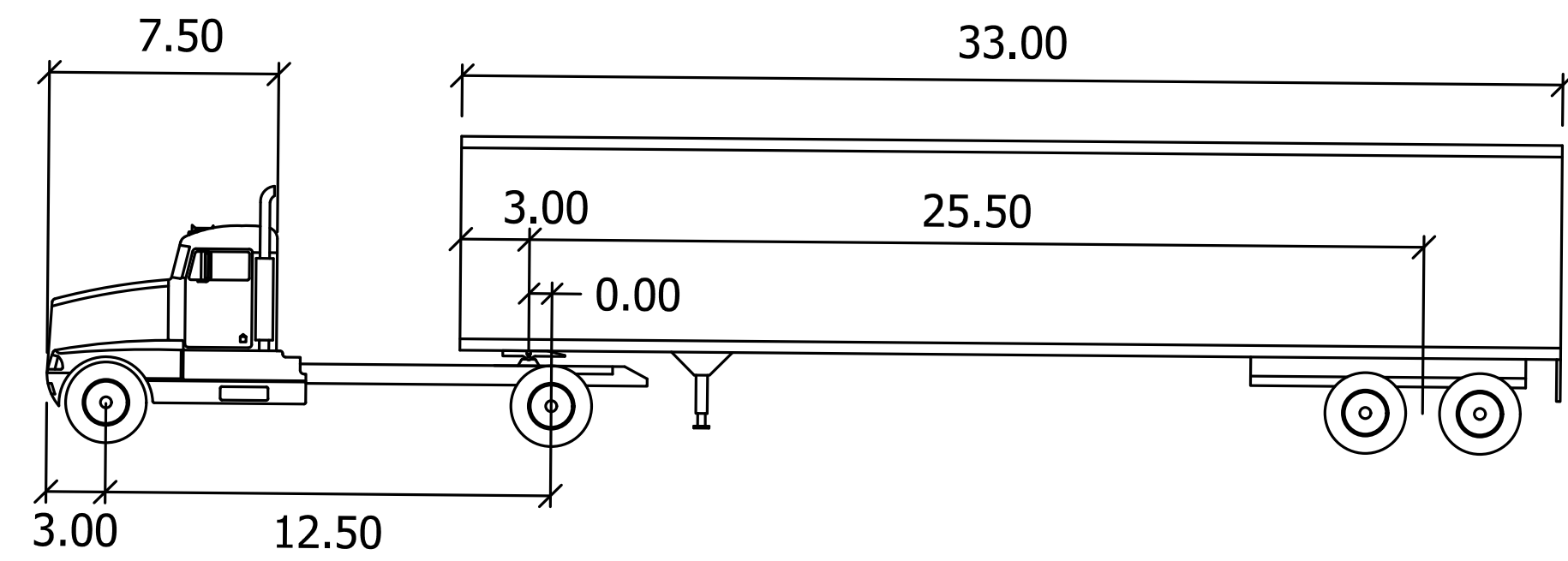
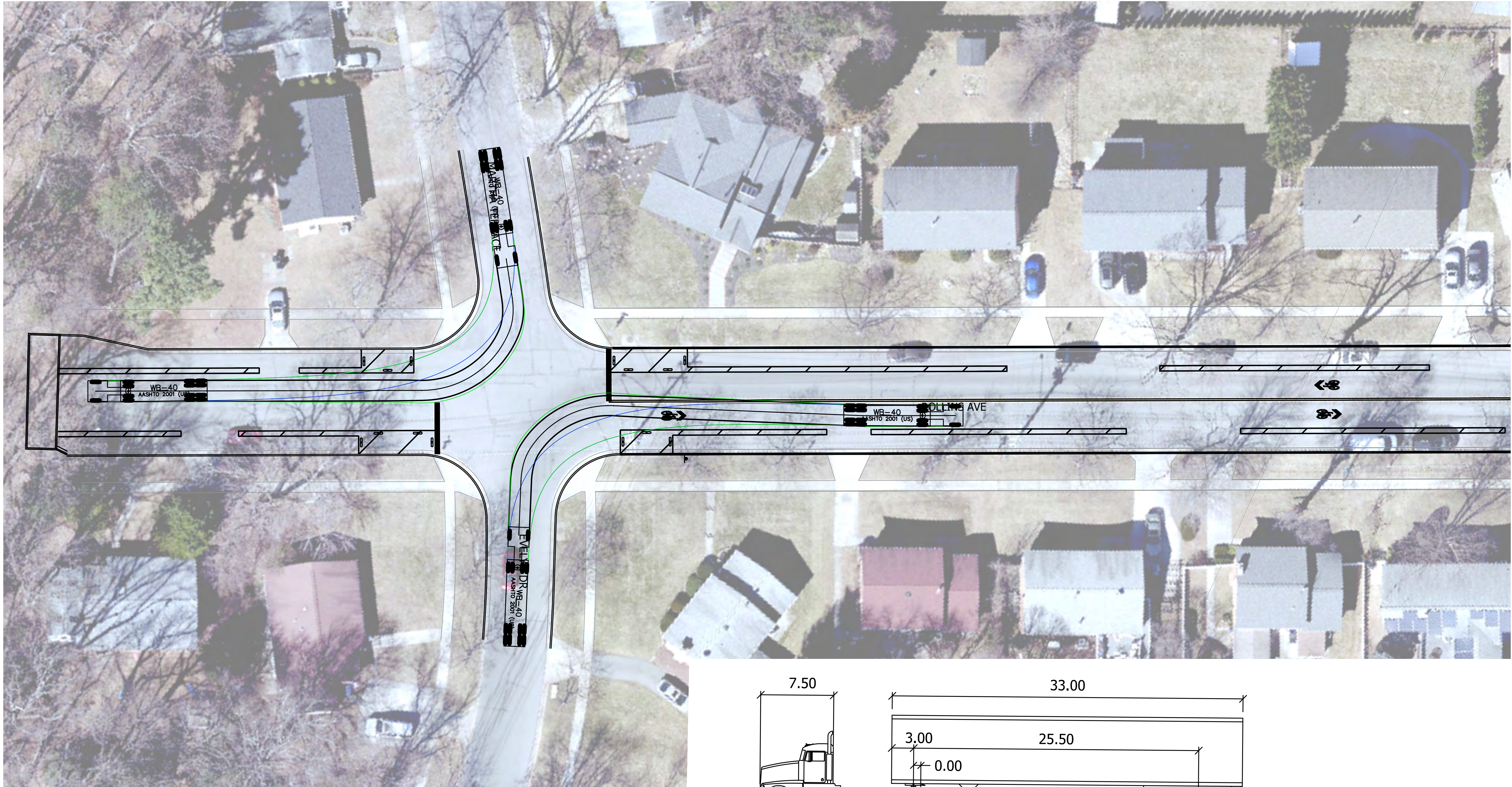

WB-40

	feet		
Tractor Width	: 8.00	Lock to Lock Time	: 6.0
Trailer Width	: 8.00	Steering Angle	: 20.3
Tractor Track	: 8.00	Articulating Angle	: 70.0
Trailer Track	: 8.00		

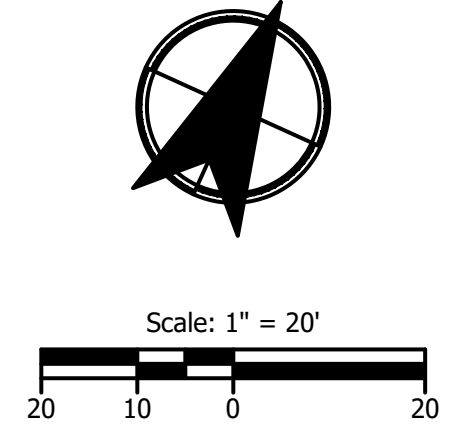

PRELIMINARY
 NOT FOR
 CONSTRUCTION

#	DATE	REVISION	APP'D

Submission Date:
 6/30/2026
 Drawn: EAA Designed: EAA Checked: CKM
 PROJECT NO.
 31213.003

ROLINS AVENUE COMPLETE STREET STUDY
 CONTROL VEHICLE MANEUVER ALT 1

SHEET NO.
 AT-02

Plot Stamp: 6/30/2026 10:34:23 AM - Erika Adams
 File: H:\31\31219 - MWCOC TLC and RSP On-Call\003 - Rollins-Twinbrook Complete Street Study\design\CD\31219.003-CD-SSPLAN-ALT 1.dwg

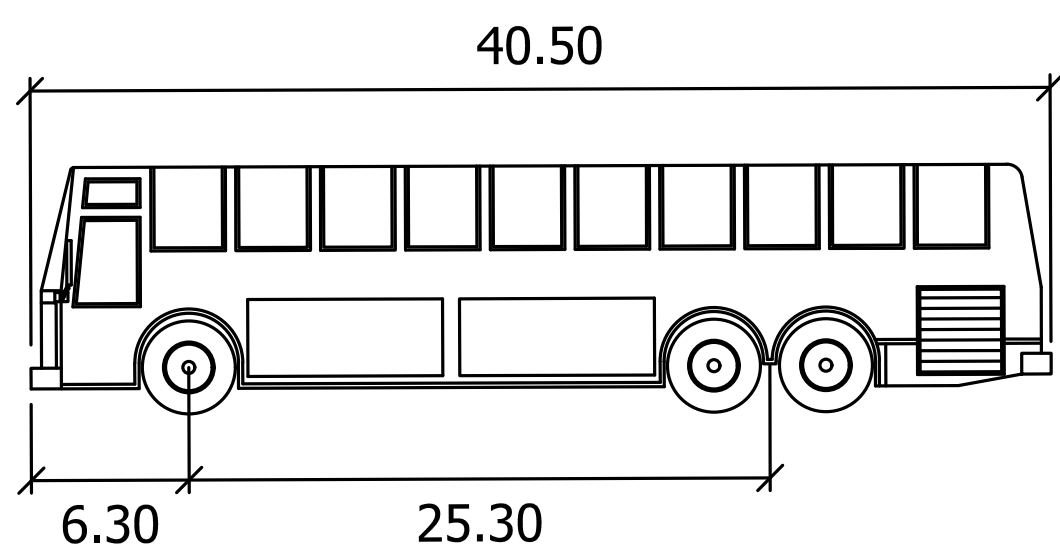
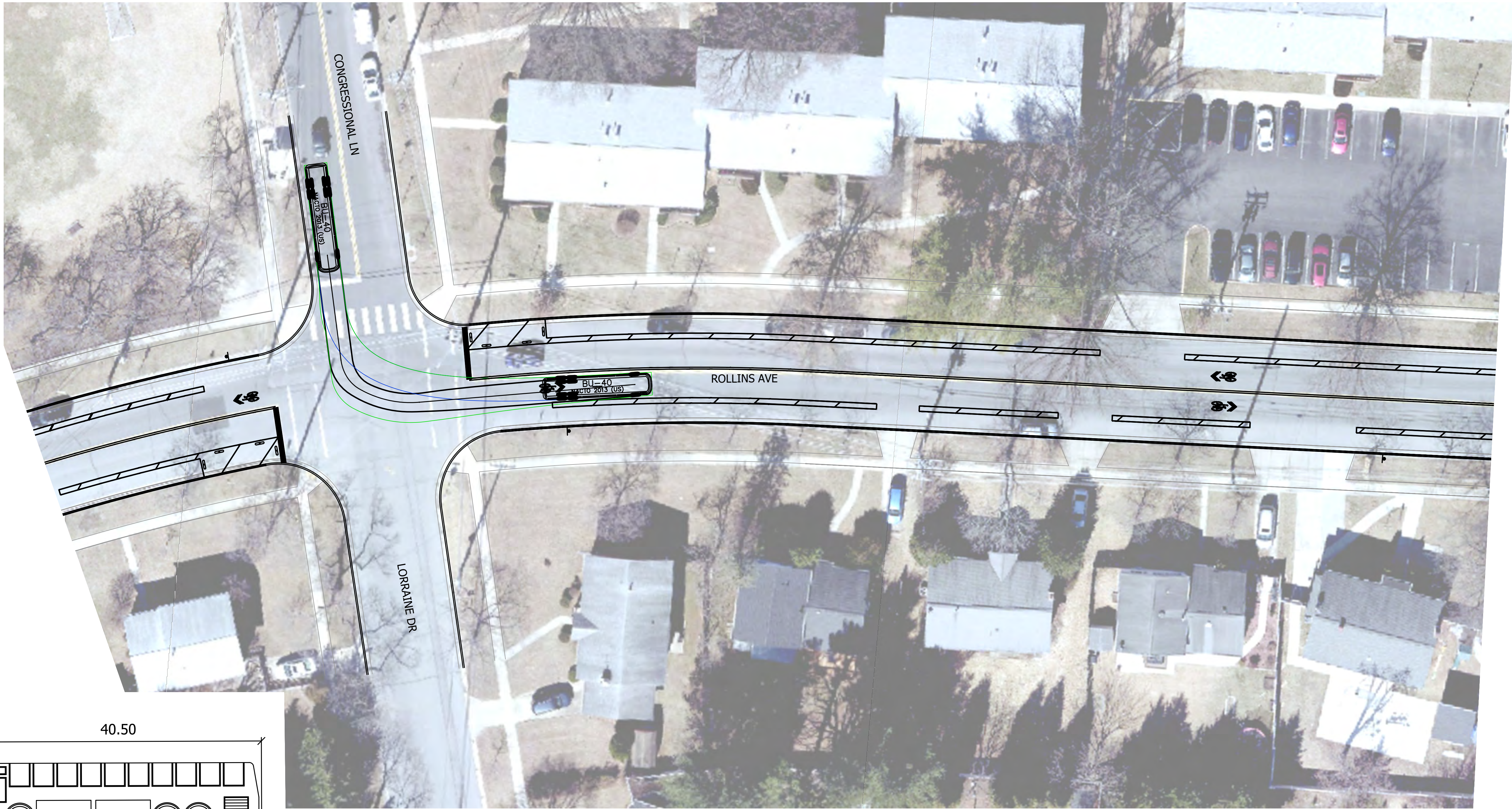

BU-40

	feet
Width	: 8.50
Track	: 8.50
Lock to Lock Time	: 6.0
Steering Angle	: 41.9

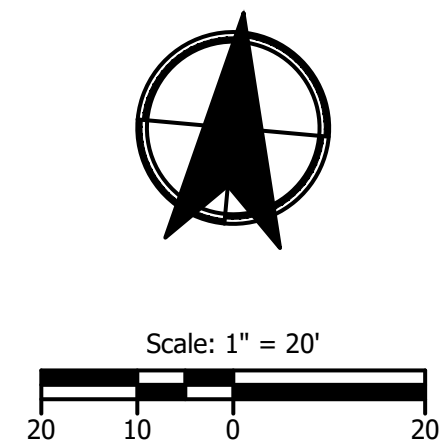

PRELIMINARY
 NOT FOR
 CONSTRUCTION



KITTELSON & ASSOCIATES
 100 M STREET SE, SUITE 910
 WASHINGTON, DC 20003
 P 202.450.3710

#	DATE	REVISION	APP'D.

Submission Date:
 6/30/2026
 Drawn: EAA Designed: EAA Checked: CKM

PROJECT NO.
 31213.003

ROLLINS AVENUE COMPLETE STREET STUDY
 CONTROL VEHICLE MANEUVER ALT 1

SHEET NO.
 AT-03

Plot Stamp: 6/30/2026 10:34:25 AM - Erika Adams
 File: H:\31\31219 - MCOG TLC and RSP On-Call\003 - Rollins-Twinbrook Complete Street Study\design\CD\31219.003-CD-SSPLAN-ALT 1.dwg

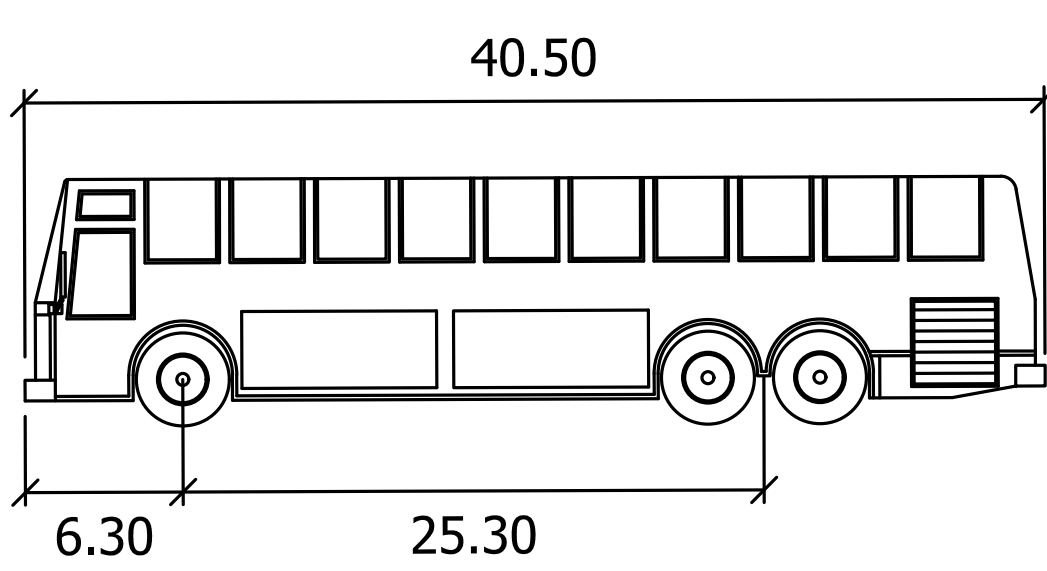
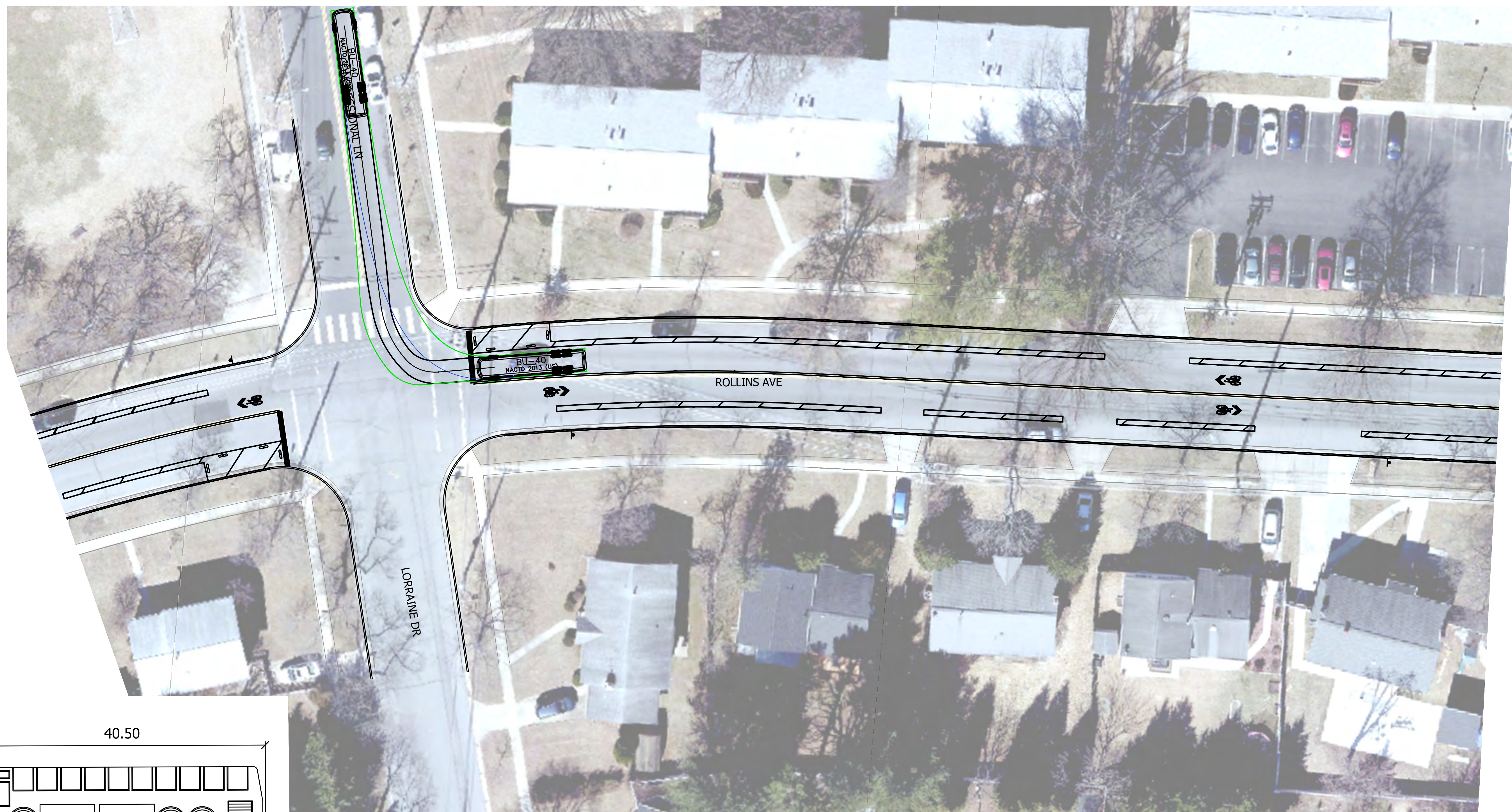

BU-40

	feet
Width	: 8.50
Track	: 8.50
Lock to Lock Time	: 6.0
Steering Angle	: 41.9

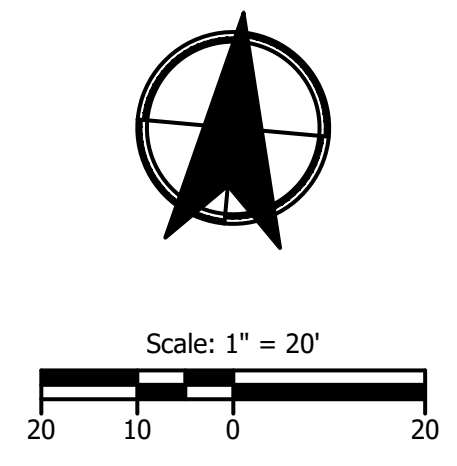

PRELIMINARY
 NOT FOR
 CONSTRUCTION



KITTELSON & ASSOCIATES
 100 M STREET SE, SUITE 910
 WASHINGTON, DC 20003
 P 202.450.3710

#	DATE	REVISION	APP'D

Submission Date:
 6/30/2026
 Drawn: EAA Designed: EAA Checked: CKM

PROJECT NO.
 31213.003

ROLLINS AVENUE COMPLETE STREET STUDY
 CONTROL VEHICLE MANEUVER ALT 1

SHEET NO.
 AT-04

Plot Stamp: 6/30/2026 10:34:27 AM - Erika Adams
 File: H:\31\31219 - MCOG TLC and RSP On-Call\003 - Rollins-Twinbrook Complete Street Study\design\CD\31219.003-CD-SSPLAN-ALT 1.dwg

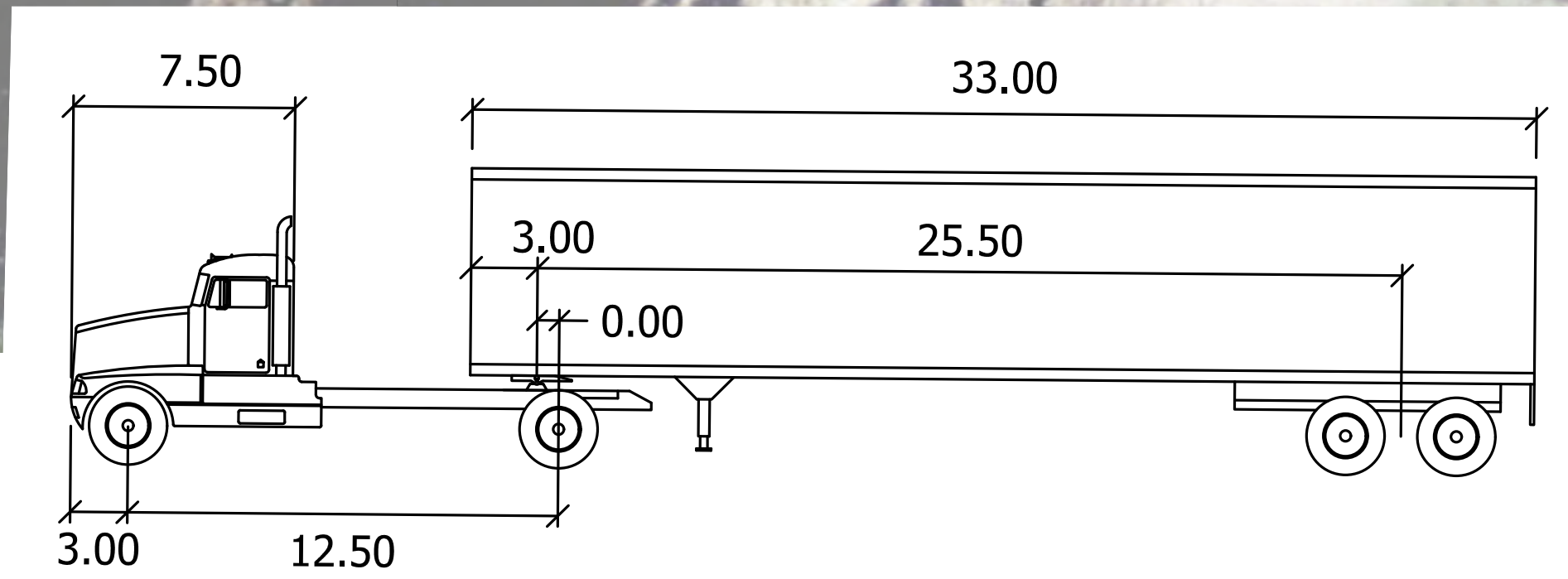
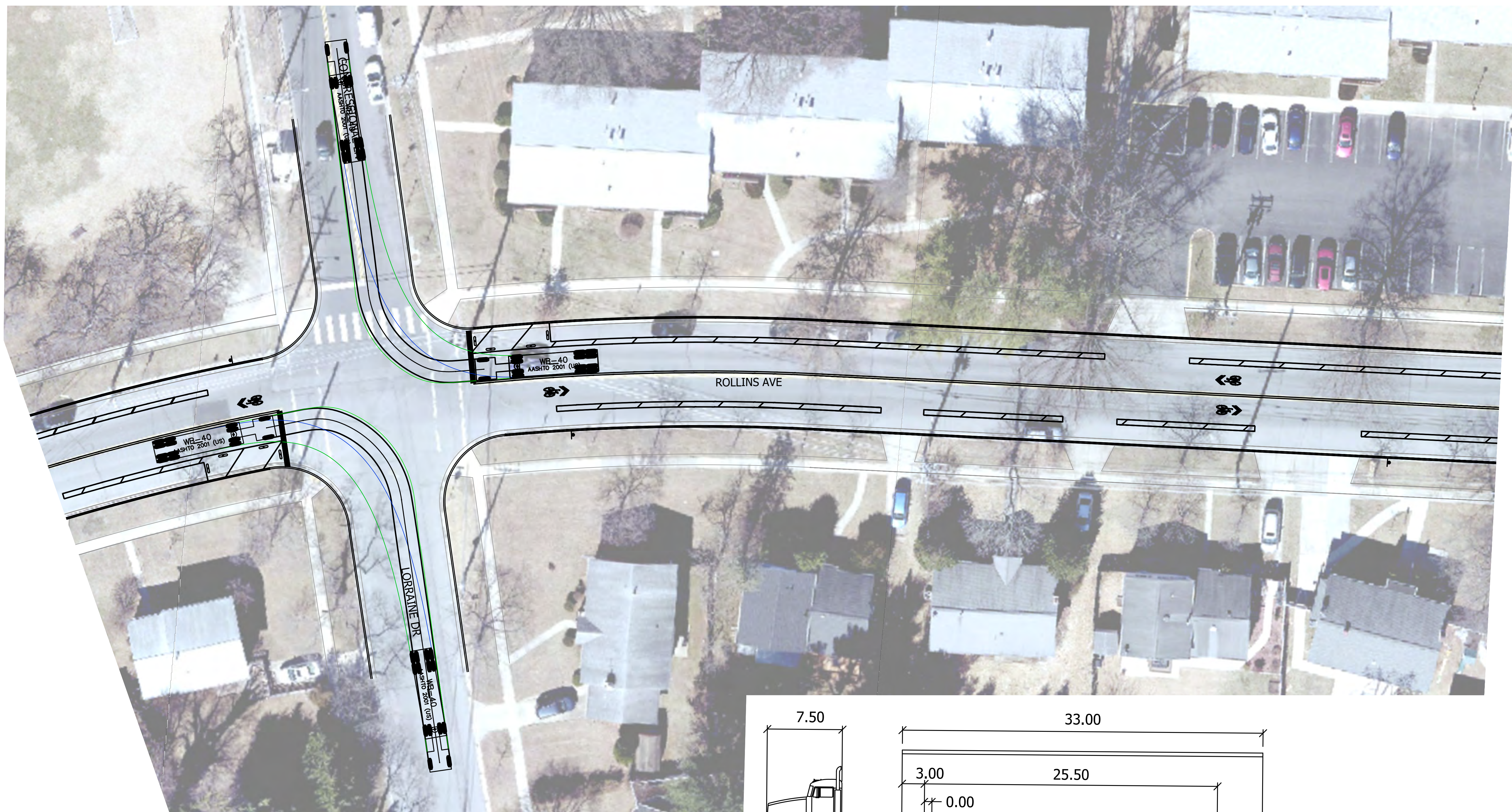

WB-40

	feet		
Tractor Width	: 8.00	Lock to Lock Time	: 6.0
Trailer Width	: 8.00	Steering Angle	: 20.3
Tractor Track	: 8.00	Articulating Angle	: 70.0
Trailer Track	: 8.00		

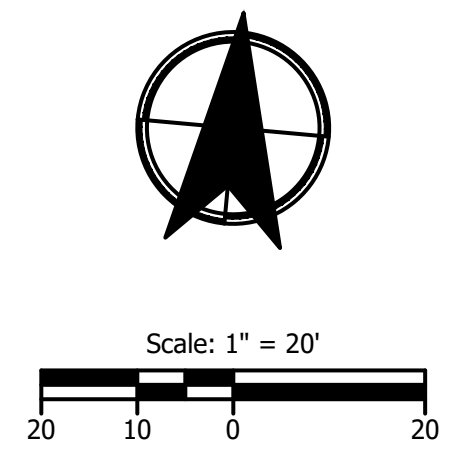

PRELIMINARY
 NOT FOR
 CONSTRUCTION



KITTELSON & ASSOCIATES
 100 M STREET SE, SUITE 910
 WASHINGTON, DC 20003
 P 202.450.3710

#	DATE	REVISION	APP'D

Submission Date: 6/30/2026
 Drawn: EAA Designed: EAA Checked: CKM

PROJECT NO. 31213.003

ROLINS AVENUE COMPLETE STREET STUDY
 CONTROL VEHICLE MANEUVER ALT 1

SHEET NO. AT-05

Plot Stamp: 6/30/2026 10:34:29 AM - Erika Adams
 File: H:\31\31219 - MCOG TLC and RSP On-Call\003 - Rollins-Twinbrook Complete Street Study\design\CD\31219.003-CD-SSPLAN-ALT 1.dwg

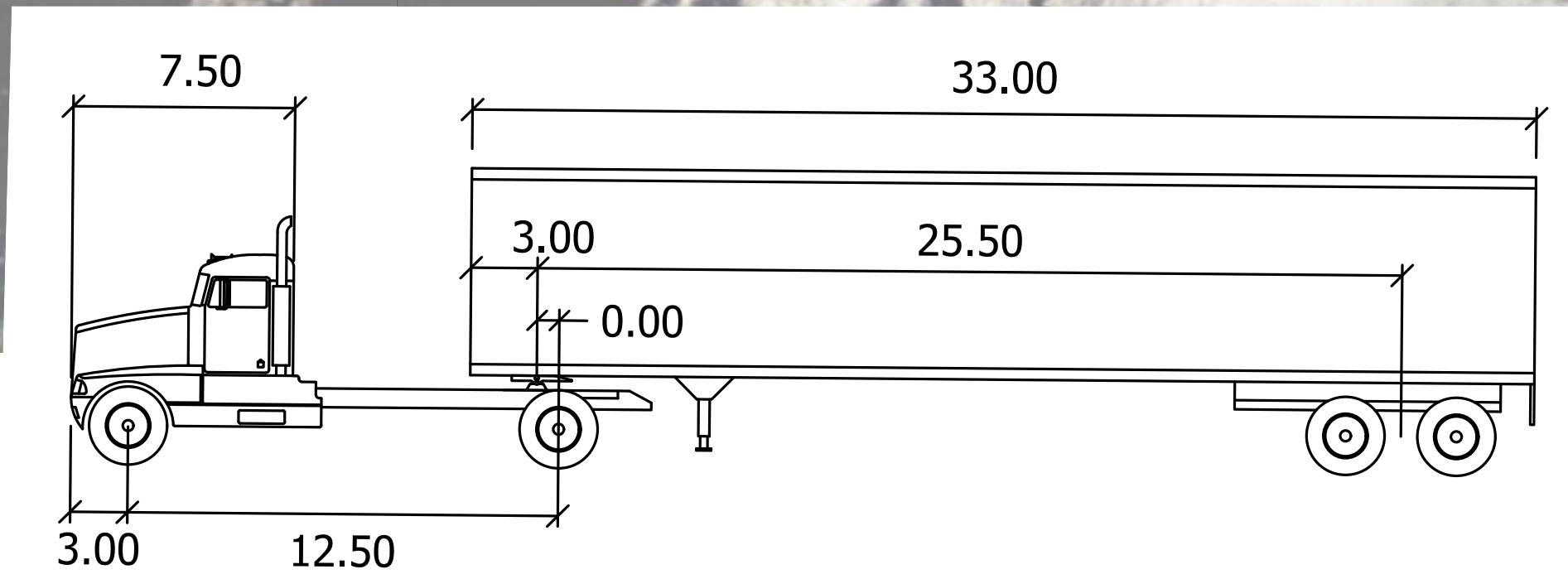
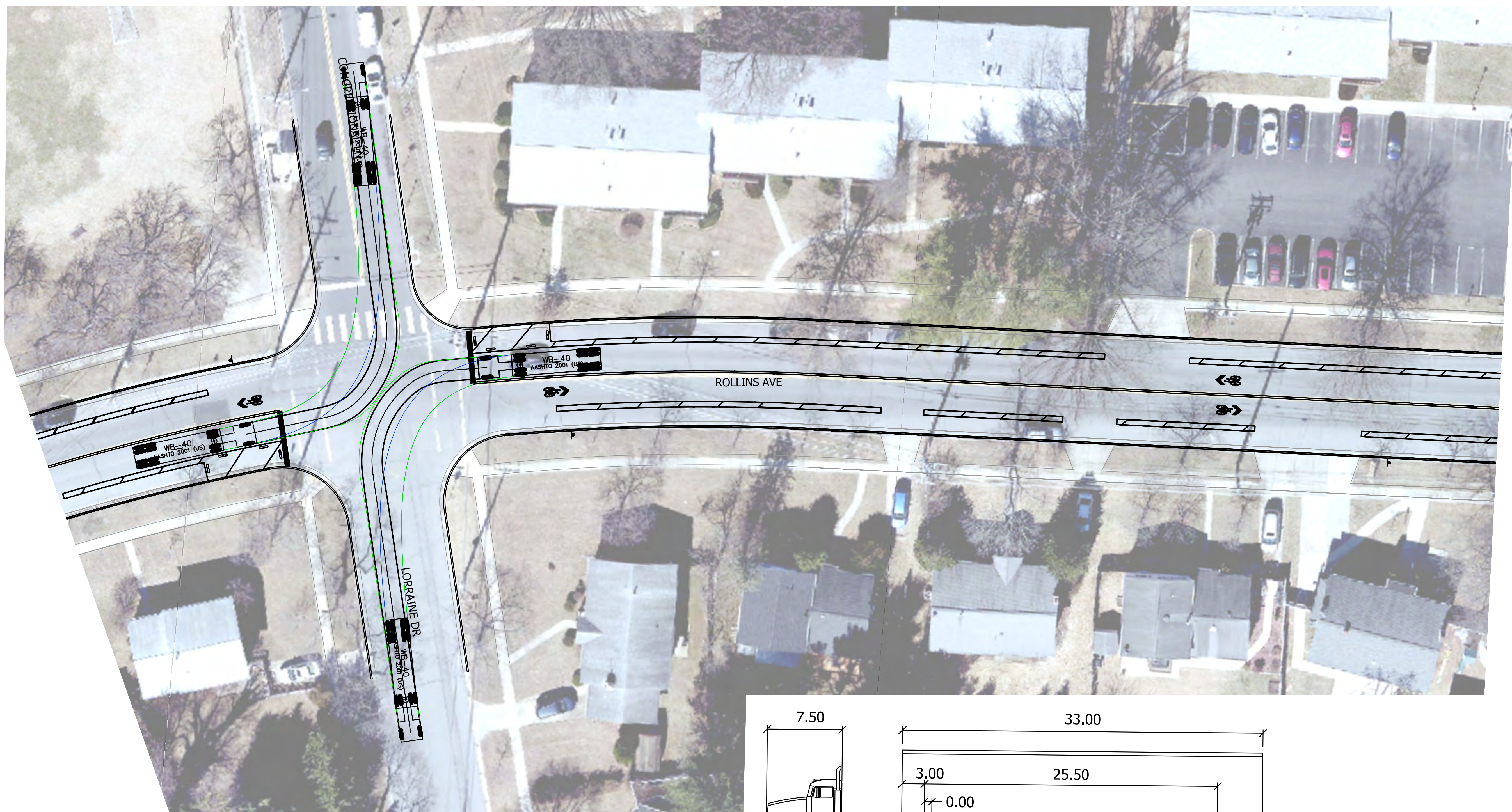

WB-40

	feet		
Tractor Width	: 8.00	Lock to Lock Time	: 6.0
Trailer Width	: 8.00	Steering Angle	: 20.3
Tractor Track	: 8.00	Articulating Angle	: 70.0
Trailer Track	: 8.00		

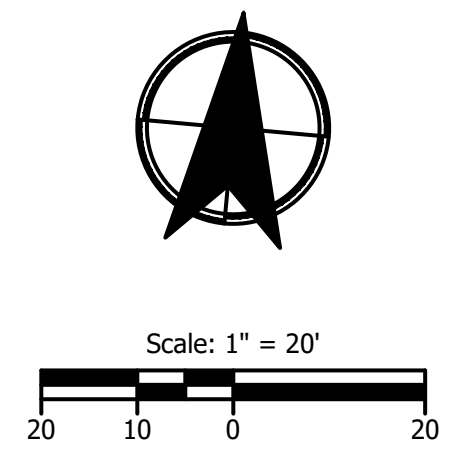

PRELIMINARY
 NOT FOR
 CONSTRUCTION



KITTELSON & ASSOCIATES
 100 M STREET SE, SUITE 910
 WASHINGTON, DC 20003
 P 202.450.3710

#	DATE	REVISION	APP'D

Submission Date:
 6/30/2026
 Drawn: EAA Designed: EAA Checked: CKM
 PROJECT NO.
 31213.003

ROLINS AVENUE COMPLETE STREET STUDY
 CONTROL VEHICLE MANEUVER ALT 1
 SHEET NO.
 AT-06

Plot Stamp: 6/30/2026 10:34:31 AM - Erika Adams
 File: H:\31\31219 - MCOG TLC and RSP On-Call\003 - Rollins-Twinbrook Complete Street Study\design\CD\31219.003-CD-SSPLAN-ALT 1.dwg

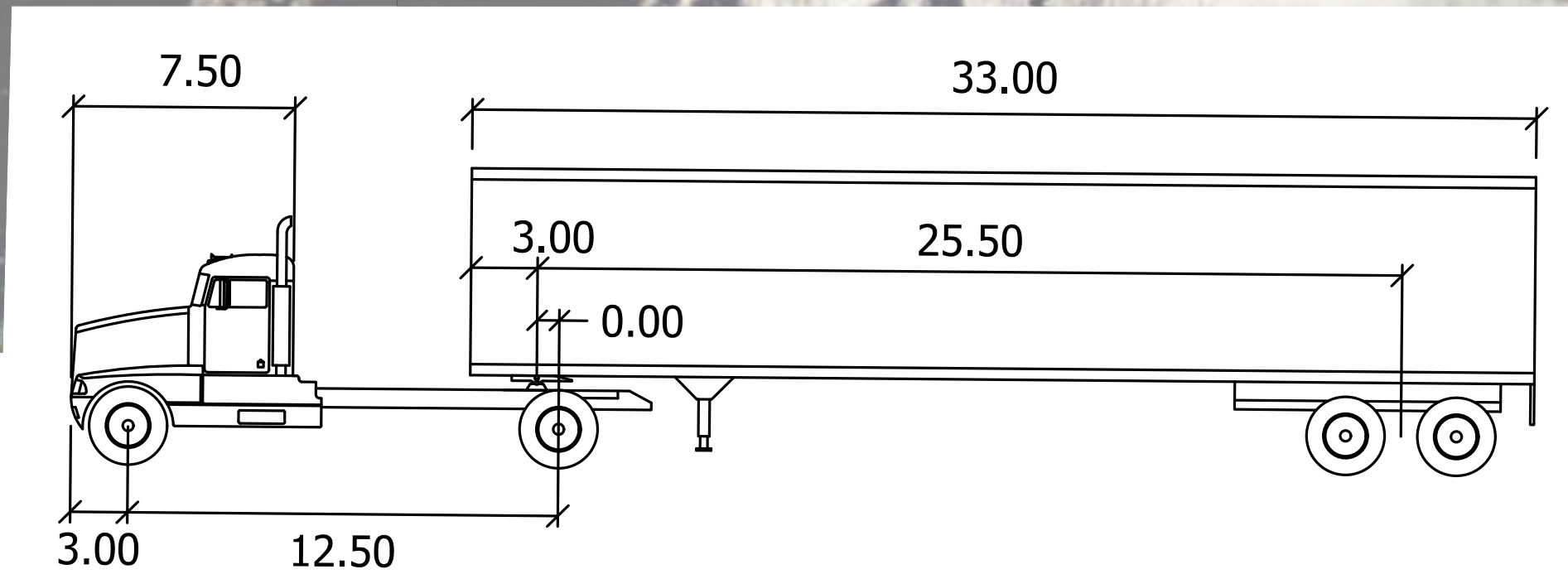
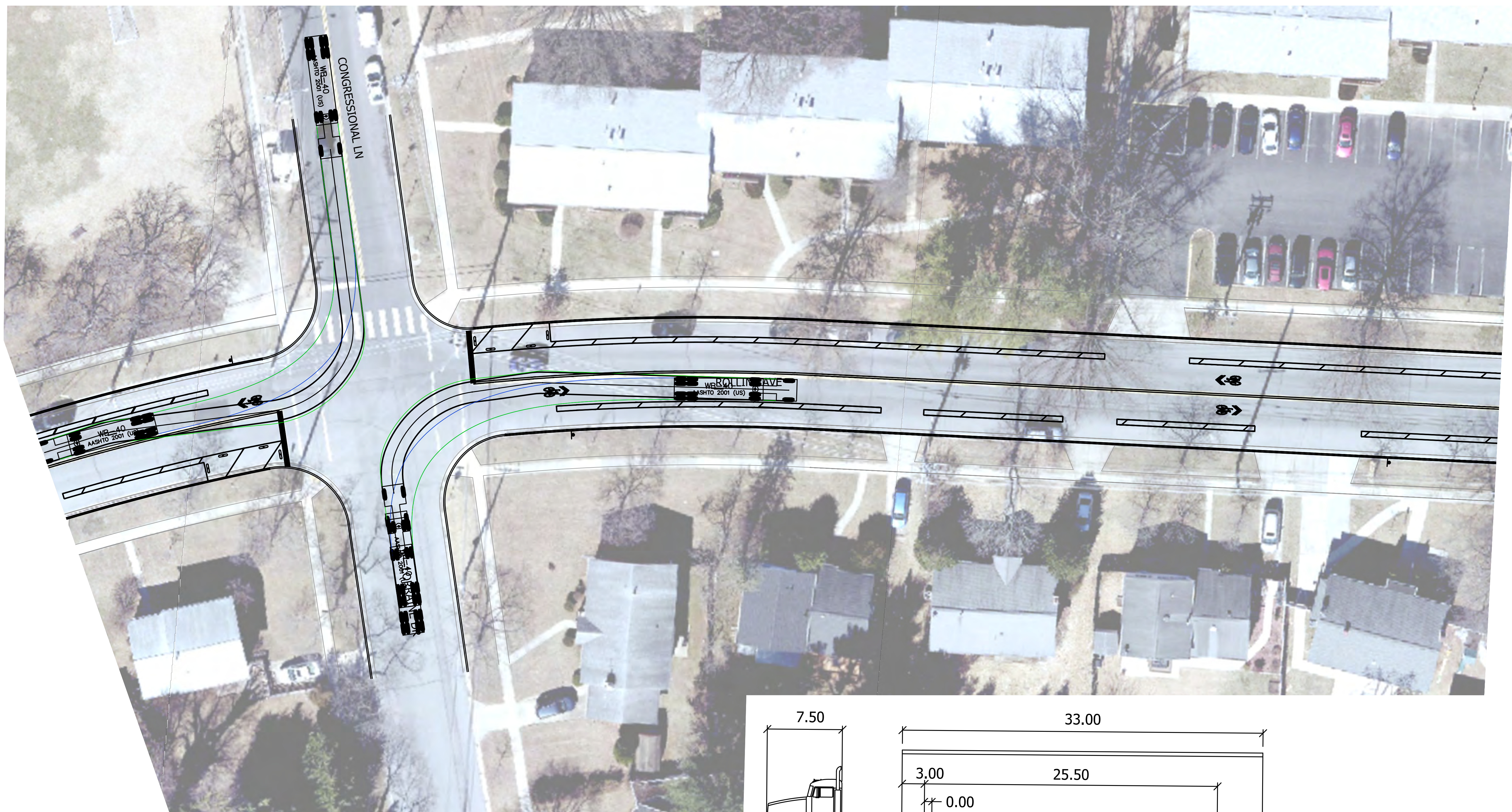

WB-40

	feet		
Tractor Width	: 8.00	Lock to Lock Time	: 6.0
Trailer Width	: 8.00	Steering Angle	: 20.3
Tractor Track	: 8.00	Articulating Angle	: 70.0
Trailer Track	: 8.00		

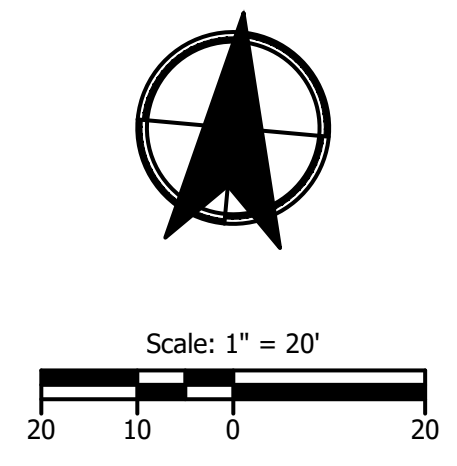

PRELIMINARY
 NOT FOR
 CONSTRUCTION



KITTELSON & ASSOCIATES
 100 M STREET SE, SUITE 910
 WASHINGTON, DC 20003
 P 202.450.3710

#	DATE	REVISION	APP'D

Submission Date:
 6/30/2026
 Drawn: EAA Designed: EAA Checked: CKM

PROJECT NO.
31213.003

ROLINS AVENUE COMPLETE STREET STUDY

CONTROL VEHICLE MANEUVER ALT 1

SHEET NO.
AT-07

Plot Stamp: 6/30/2026 10:34:32 AM - Erika Adams
 File: H:\31\31219 - MCOG TLC and RSP On-Call\003 - Rollins-Twinbrook Complete Street Study\design\CD\31219.003-CD-SSPLAN-ALT 1.dwg

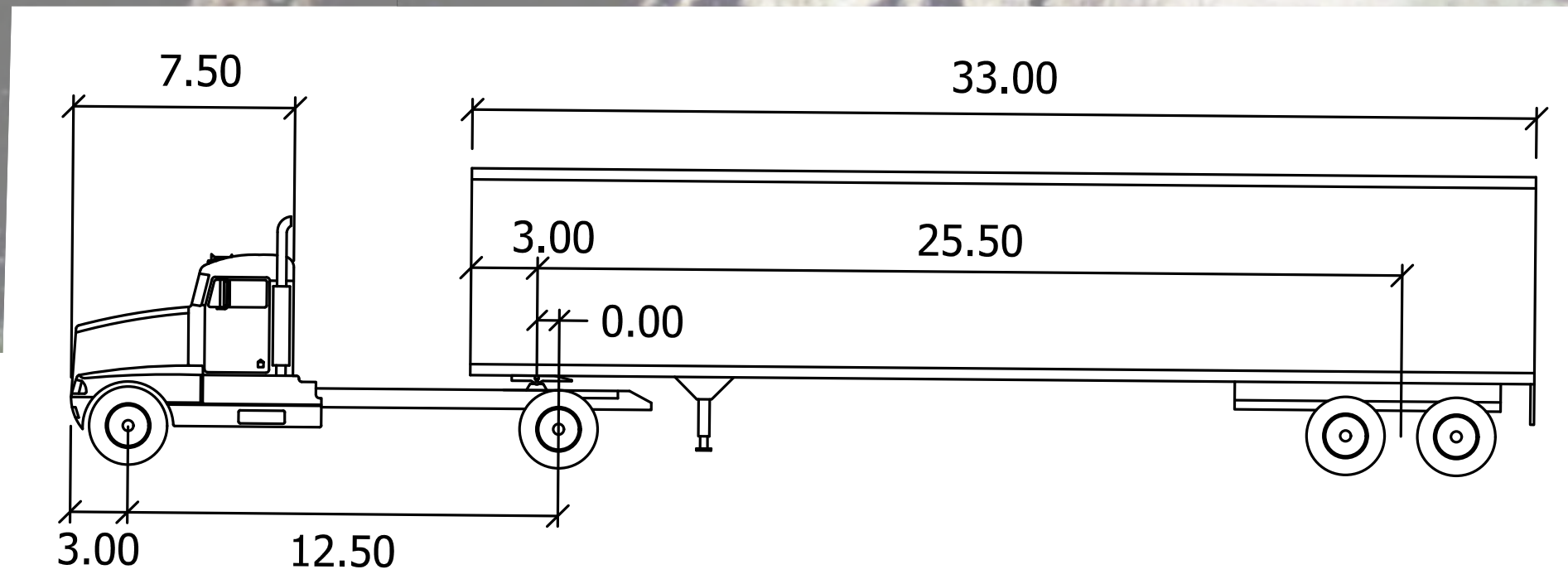
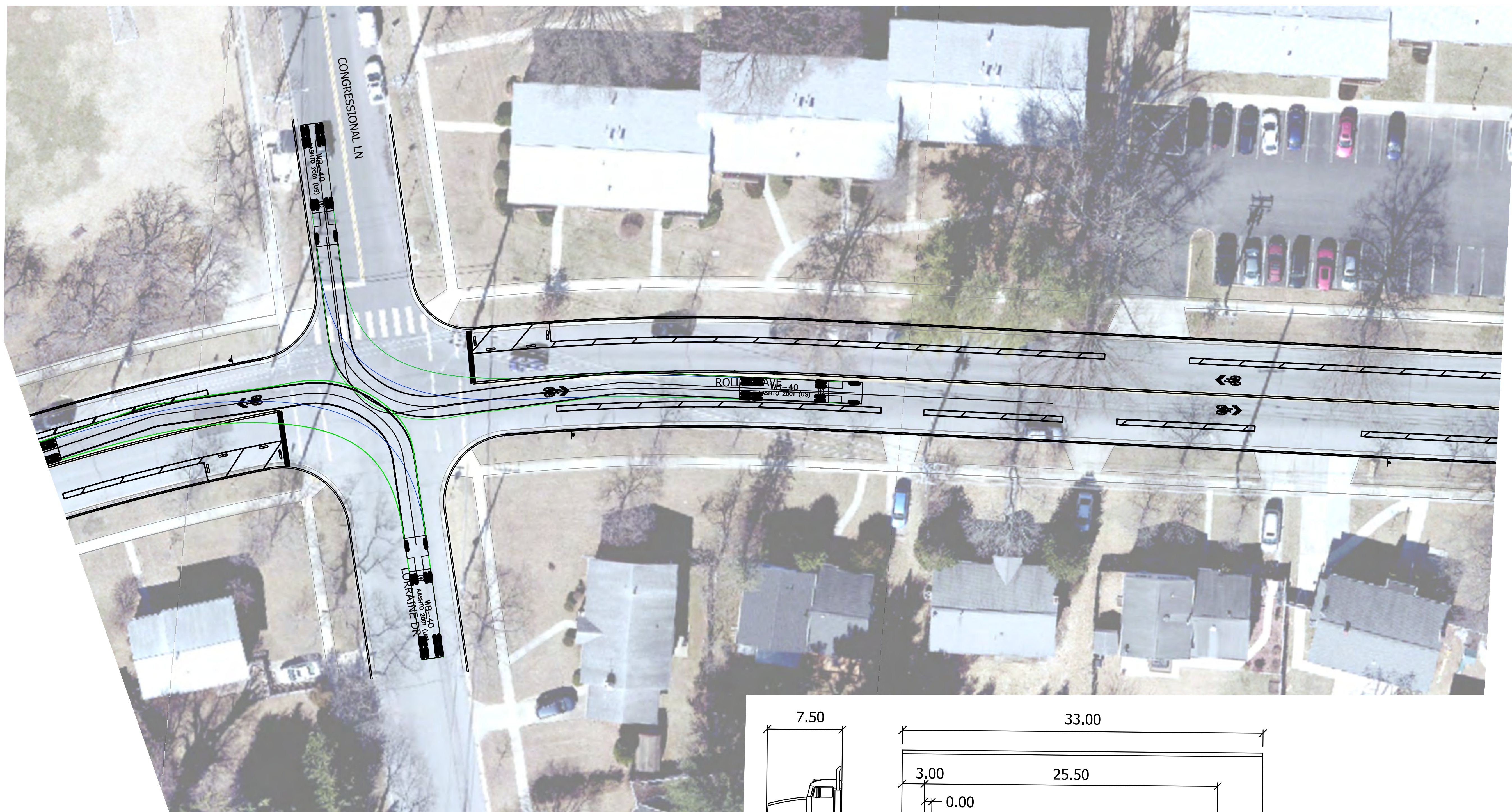

WB-40

	feet		
Tractor Width	: 8.00	Lock to Lock Time	: 6.0
Trailer Width	: 8.00	Steering Angle	: 20.3
Tractor Track	: 8.00	Articulating Angle	: 70.0
Trailer Track	: 8.00		

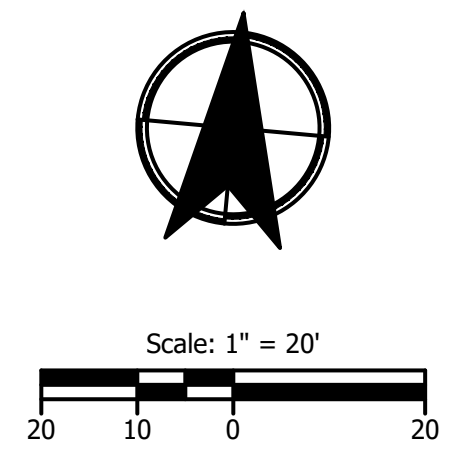

PRELIMINARY
 NOT FOR
 CONSTRUCTION



KITTELSON & ASSOCIATES
 100 M STREET SE, SUITE 910
 WASHINGTON, DC 20003
 P 202.450.3710

#	DATE	REVISION	APP'D

Submission Date:
 6/30/2026
 Drawn: EAA Designed: EAA Checked: CKM

PROJECT NO.
31213.003
ROLINS AVENUE COMPLETE STREET STUDY
 CONTROL VEHICLE MANEUVER ALT 1
 SHEET NO.
AT-08

Plot Stamp: 6/30/2026 10:34:35 AM - Erika Adams
 File: H:\31\31219 - MCOG TLC and RSP On-Call\003 - Rollins-Twinbrook Complete Street Study\Design_CD\31219.003-CD-SSPLAN-ALT 1.dwg

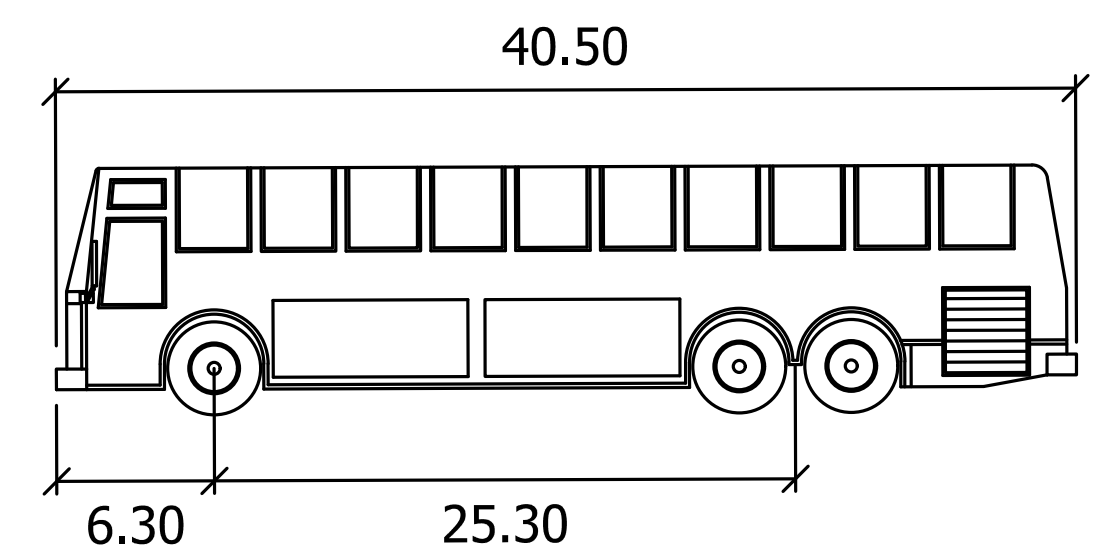
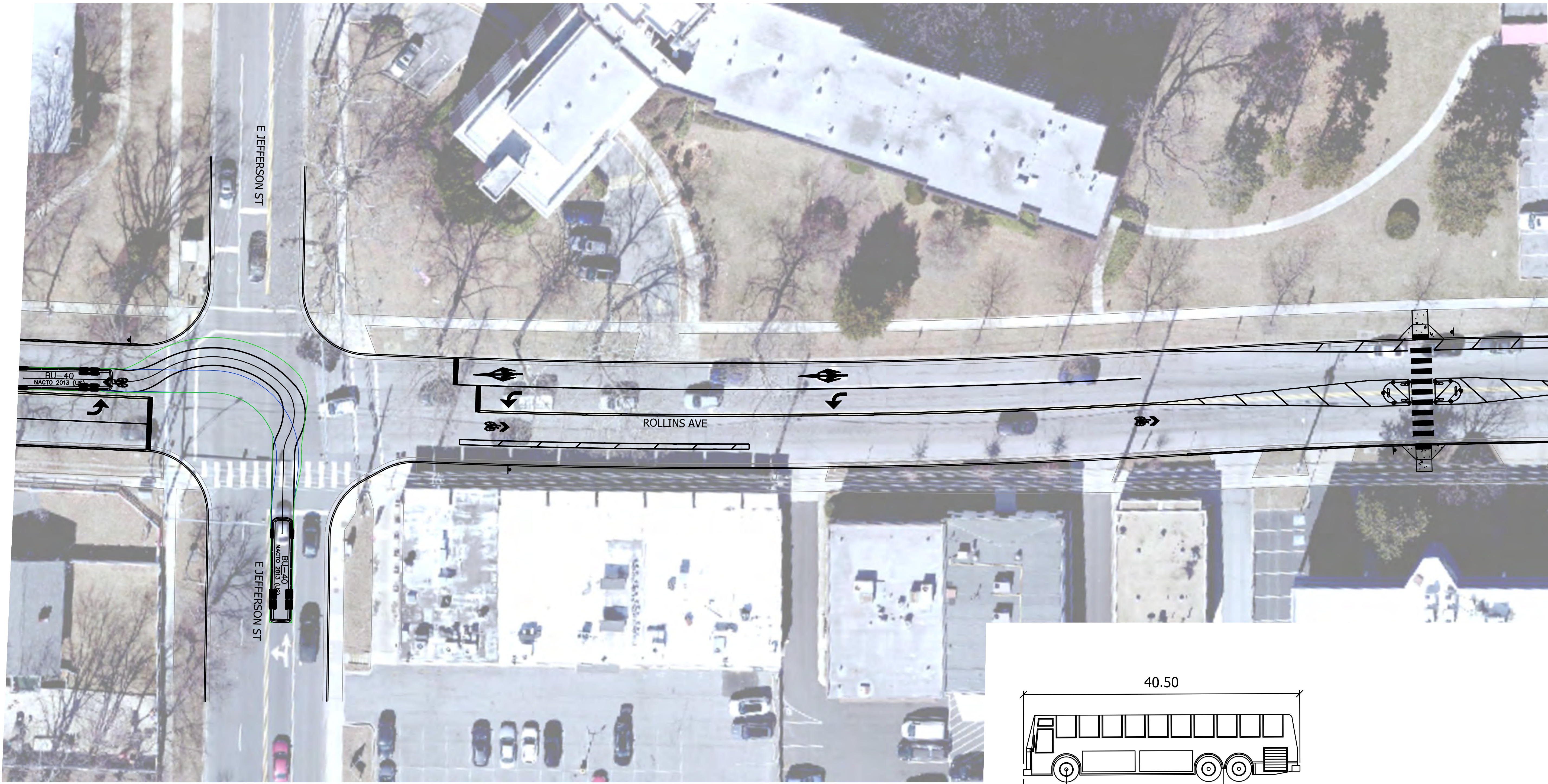

BU-40

	feet
Width	: 8.50
Track	: 8.50
Lock to Lock Time	: 6.0
Steering Angle	: 41.9

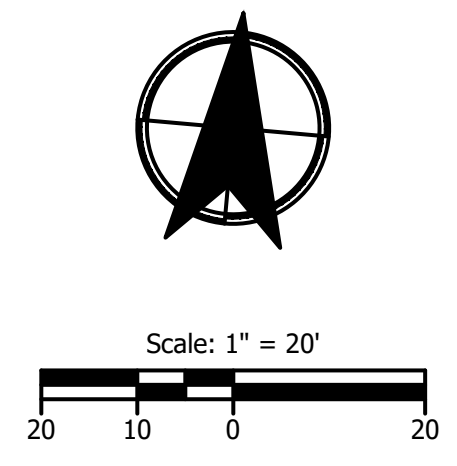

PRELIMINARY
 NOT FOR
 CONSTRUCTION



KITTELSON & ASSOCIATES
 100 M STREET SE, SUITE 910
 WASHINGTON, DC 20003
 P 202.450.3710

#	DATE	REVISION	APP'D

Submission Date:
 6/30/2026
 Drawn: EAA Designed: EAA Checked: CKM

PROJECT NO.
31213.003

ROLINS AVENUE COMPLETE STREET STUDY

CONTROL VEHICLE MANEUVER ALT 1

SHEET NO.
AT-09

Plot Stamp: 6/30/2026 10:34:37 AM - Erika Adams
 File: H:\31\31219 - MCOG TLC and RSP On-Call\003 - Rollins-Twinbrook Complete Street Study\design\CD\31219.003-CD-SSPLAN-ALT 1.dwg

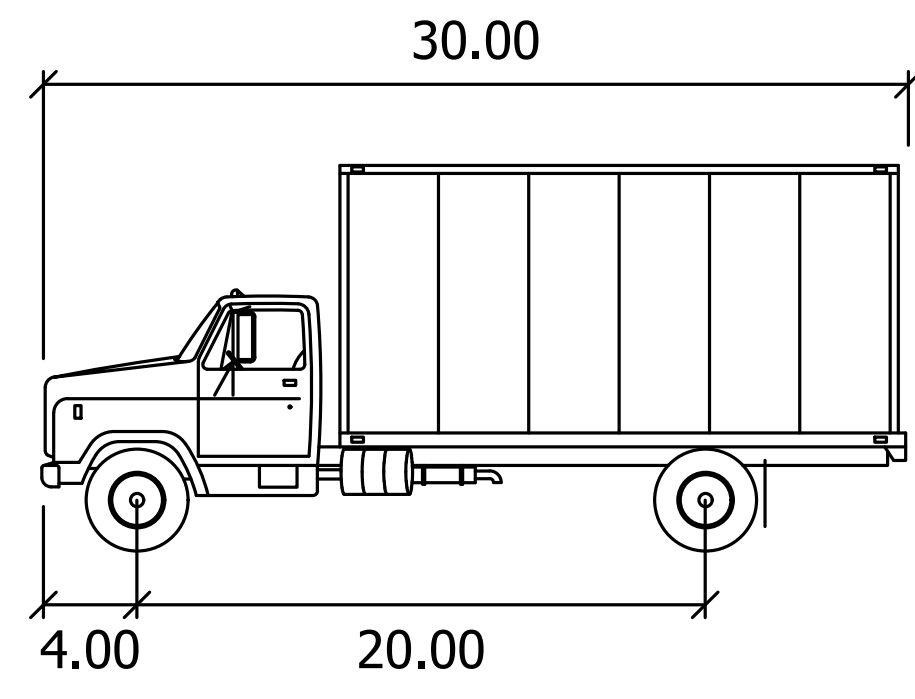
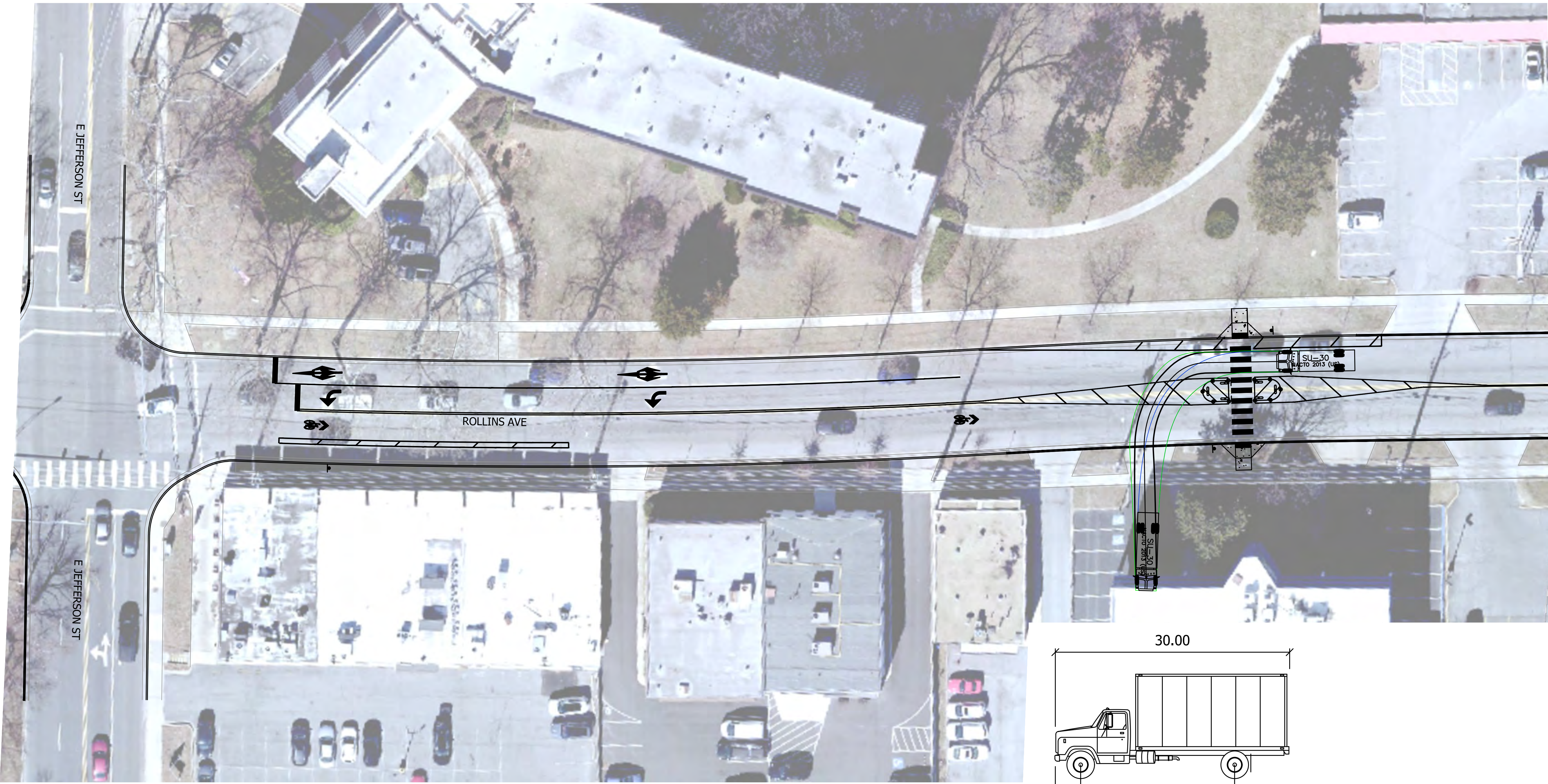

SU-30

	feet
Width	: 8.00
Track	: 8.00
Lock to Lock Time	: 6.0
Steering Angle	: 31.8

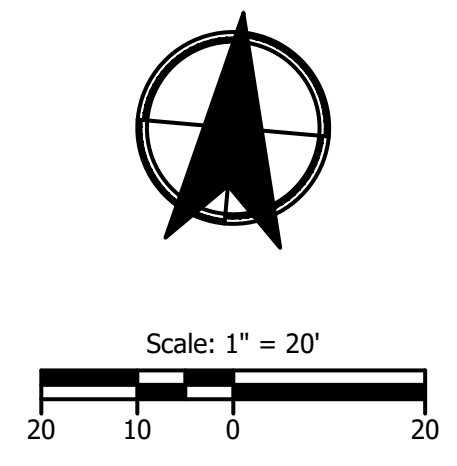

PRELIMINARY
 NOT FOR
 CONSTRUCTION



**KITTELSON
 & ASSOCIATES**
 100 M STREET SE, SUITE 910
 WASHINGTON, DC 20003
 P 202.450.3710

#	DATE	REVISION	APP'D.

Submission Date:
 6/30/2026
 Drawn: EAA Designed: EAA Checked: CKM
 PROJECT NO.
 31213.003

**ROLLINS AVENUE COMPLETE
 STREET STUDY**
 CONTROL VEHICLE MANEUVER ALT 1

SHEET NO.
 AT-10

Plot Stamp: 6/30/2026 10:34:41 AM - Erika Adams
 File: H:\31\31219 - MCOG TLC and RSP On-Call\003 - Rollins-Twinbrook Complete Street Study\design\CD\31219.003-CD-SSPLAN-ALT 1.dwg

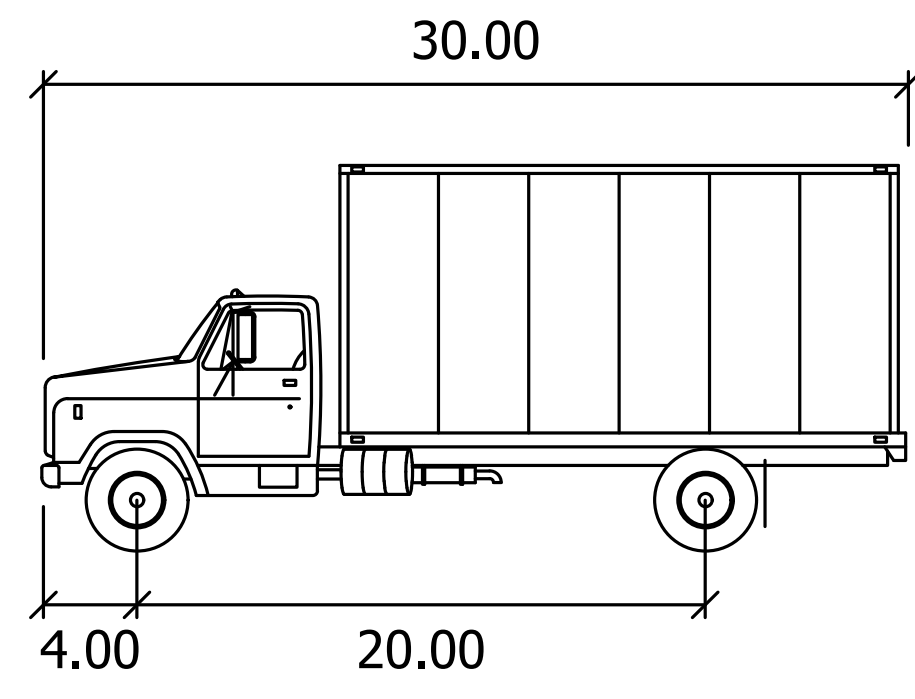
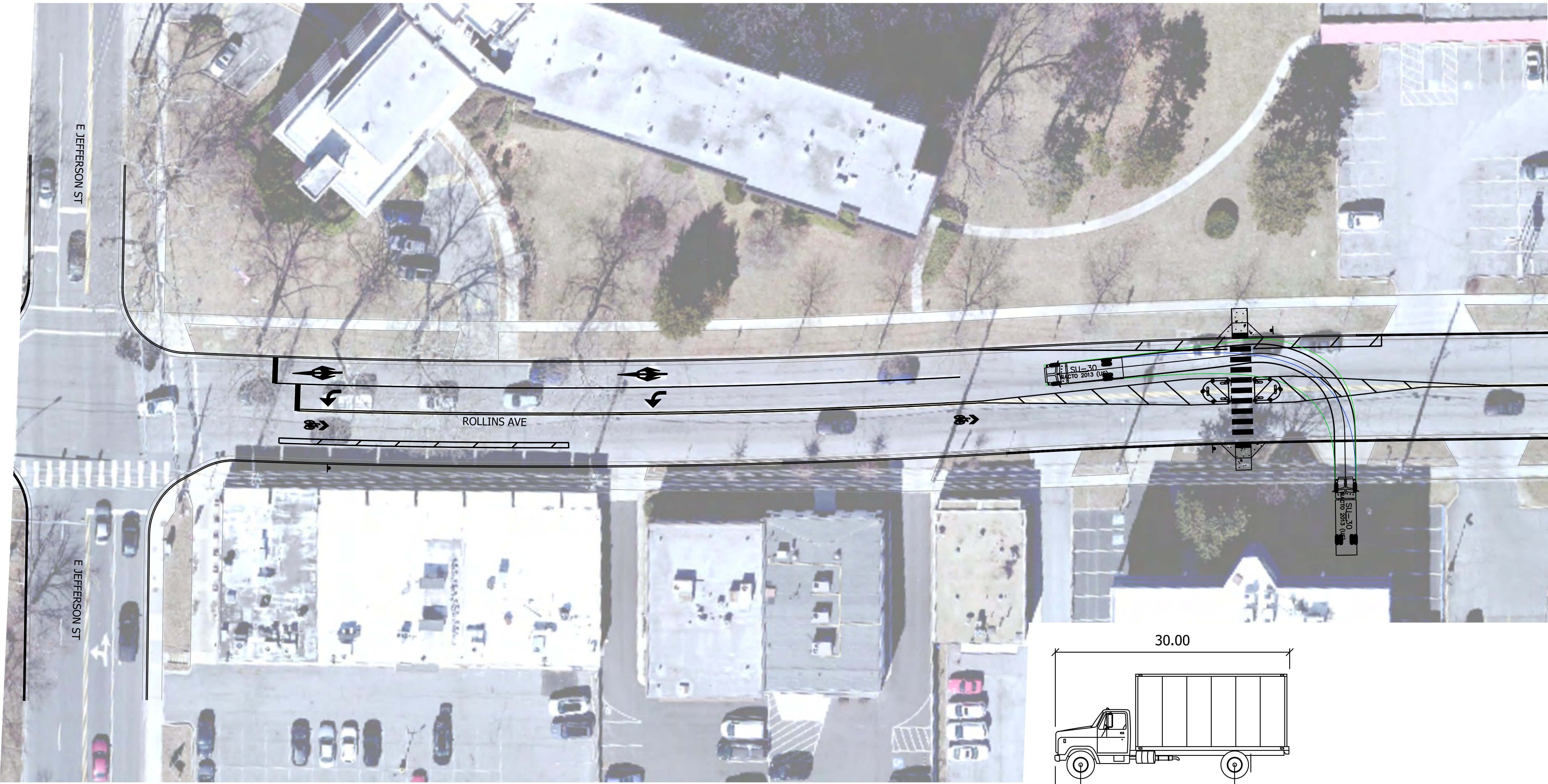

SU-30

	feet
Width	: 8.00
Track	: 8.00
Lock to Lock Time	: 6.0
Steering Angle	: 31.8

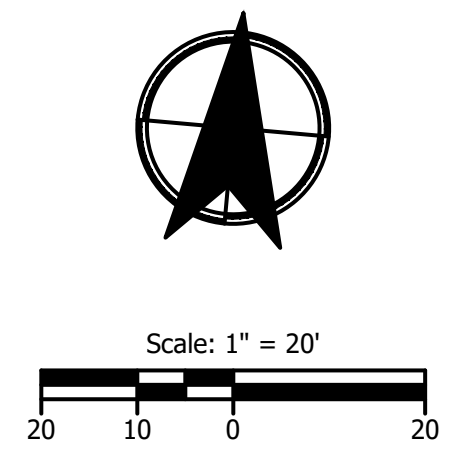

PRELIMINARY
 NOT FOR
 CONSTRUCTION



KITTELSON & ASSOCIATES
 100 M STREET SE, SUITE 910
 WASHINGTON, DC 20003
 P 202.450.3710

#	DATE	REVISION	APP'D.

Submission Date:
 6/30/2026
 Drawn: EAA Designed: EAA Checked: CKM
 PROJECT NO.
 31213.003

ROLLINS AVENUE COMPLETE STREET STUDY
 CONTROL VEHICLE MANEUVER ALT 1

SHEET NO.
 AT-11

CITY OF ROCKVILLE

CONCEPT DESIGN

ROLLINS AVENUE

Option 2: Long-Term Safety Improvements

INDEX		
DWG. NO.	SHEET NO.	PLAN TITLE
T-01	1	PROJECT LOCATION & INDEX
T-02	2	GENERAL NOTES & LEGEND
D-01	3	CONSTRUCTION DETAILS
SS-01	4	SIGNING & STRIPING PLAN ALT 2
SS-02	5	SIGNING & STRIPING PLAN ALT 2
SS-03	6	SIGNING & STRIPING PLAN ALT 2
SS-04	7	SIGNING & STRIPING PLAN ALT 2
SS-05	8	SIGNING & STRIPING PLAN ALT 2
SS-06	9	SIGNING & STRIPING PLAN ALT 2
SS-07	10	SIGNING & STRIPING PLAN ALT 2
SS-08	11	SIGN SUMMARY ALT 2

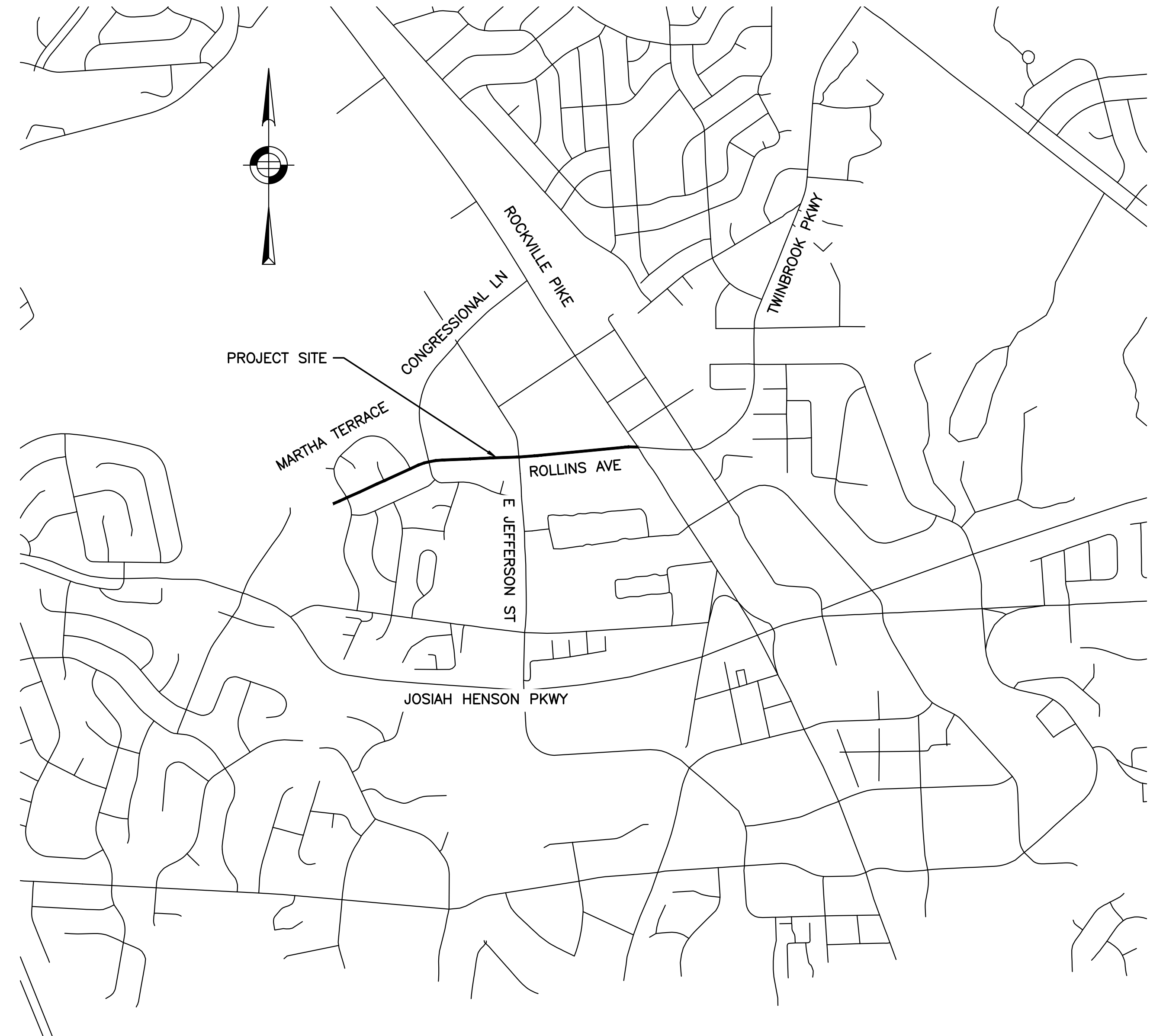

PRELIMINARY
NOT FOR
CONSTRUCTION



KITTELSON & ASSOCIATES
100 M STREET SE, SUITE 910
WASHINGTON, DC 20003
P 202.450.3710

#	DATE	REVISION	APP'D

Submission Date:
6/30/2026

Drawn: EAA	Designed: EAA	Checked: CKM
---------------	------------------	-----------------

PROJECT NO.
31213.003

ROLLINS AVENUE COMPLETE STREET STUDY

PROJECT LOCATION & INDEX

SHEET NO.
T-01













Plot Stamp: 6/30/2026 10:38:15 AM - Erika Adams
File: H:\31\31213 - MCOG TLC and RSP On-Call\003 - Rollins-Twinbrook Complete Street Study\design_CD\31213.003-CD-COVER & NOTES-ALT 2.dwg

Plot Stamp: 6/30/2026 10:38:16 AM - Erika Adams
 File: H:\31\31219 - MCOG TLC and RSP On-Call\003 - Rollins-Twinbrook Complete Street Study\design\CD\31219.003-CD-COVER & NOTES-ALT 2.dwg

ABBREVIATIONS

APRX	APPROXIMATELY
BS	BACK OF SIDEWALK
EXIST	EXISTING
LP	LIGHT POLE/LOW POINT
MNT	MOUNT
PROP	PROPOSED
R	RADIUS
REM	REMOVE
RET	RETAIN
SL	STOP LINE
CW	CROSS WALK

LEGEND

EXISTING	PROPOSED	
		NEW OR RELOCATED SIGN
		SHARED LANE MARKING
		SPEED HUMP MARKING
		CROSSWALK
		SIGN POST
		5" SOLID WHITE LINE
		5" SOLID YELLOW LINE
		2x 4" DOUBLE YELLOW CENTER LINES
		5" SOLID WHITE CHANNELIZATION LINES AT 15' O.C.
		5" SOLID YELLOW CHANNELIZATION LINES AT 15' O.C.
		24" MINIMUM WHITE STOP LINE (UNLESS OTHERWISE NOTED)

PRELIMINARY
 NOT FOR
 CONSTRUCTION



KITTELSON & ASSOCIATES
 100 M STREET SE, SUITE 910
 WASHINGTON, DC 20003
 P 202.450.3710

REVISION	DATE	APP'D

Submission Date:
 6/30/2026

Drawn: EAA	Designed: EAA	Checked: CKM
---------------	------------------	-----------------

PROJECT NO.
 31213.003

ROLINS AVENUE COMPLETE STREET STUDY
 GENERAL NOTES & LEGEND

SHEET NO.
 T-02

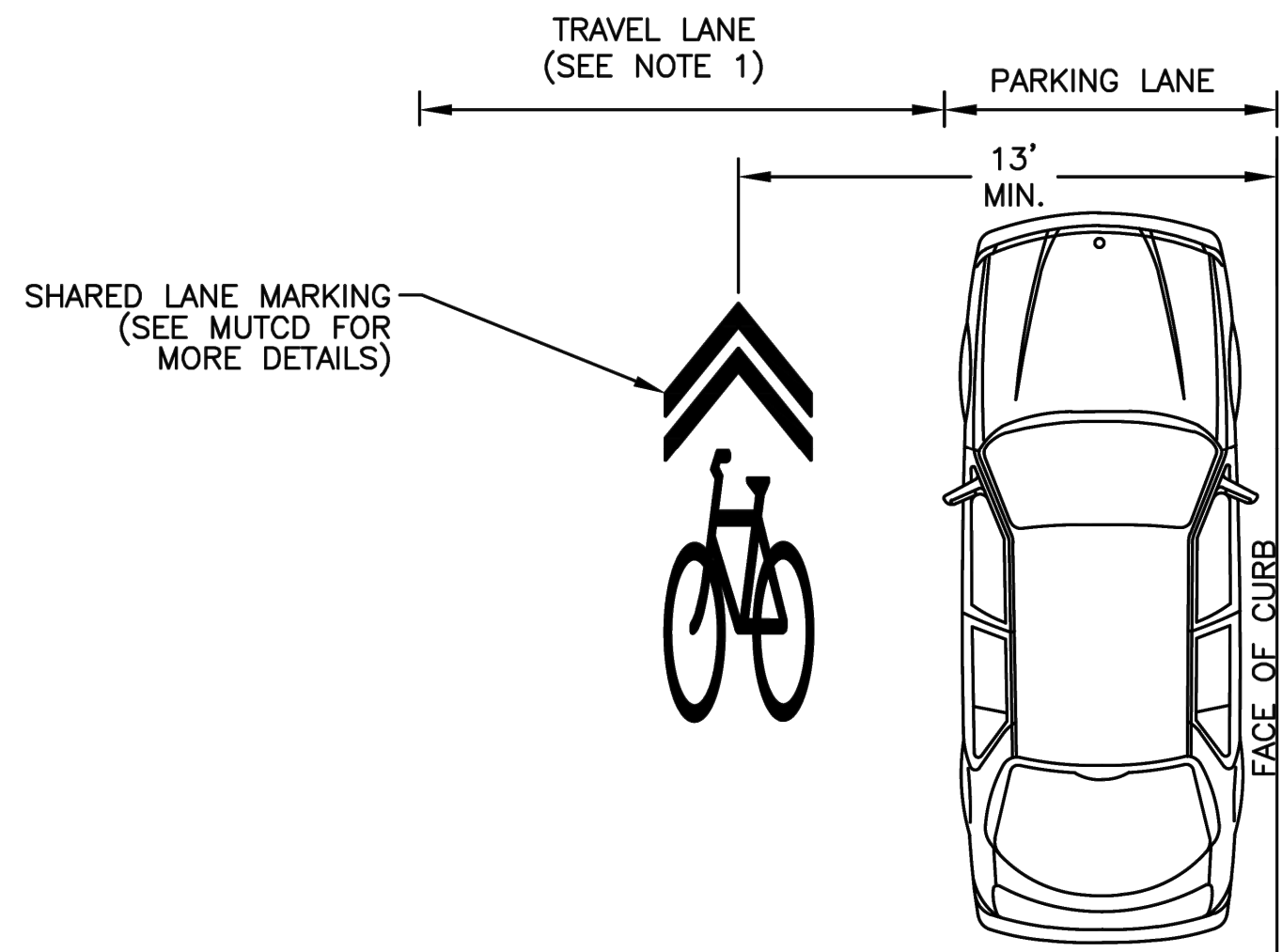

NOTES:

1. IF TRAVEL LANE IS LESS THAN 14' SHARED LANE MARKING SHALL BE CENTERED IN TRAVEL LANE.
2. DESIGN PLANS SHOULD BE CONSULTED FOR VARIATIONS.

TYPICAL SHARED LANE MARKINGS ADJACENT TO ON-STREET PARKING
N.T.S.

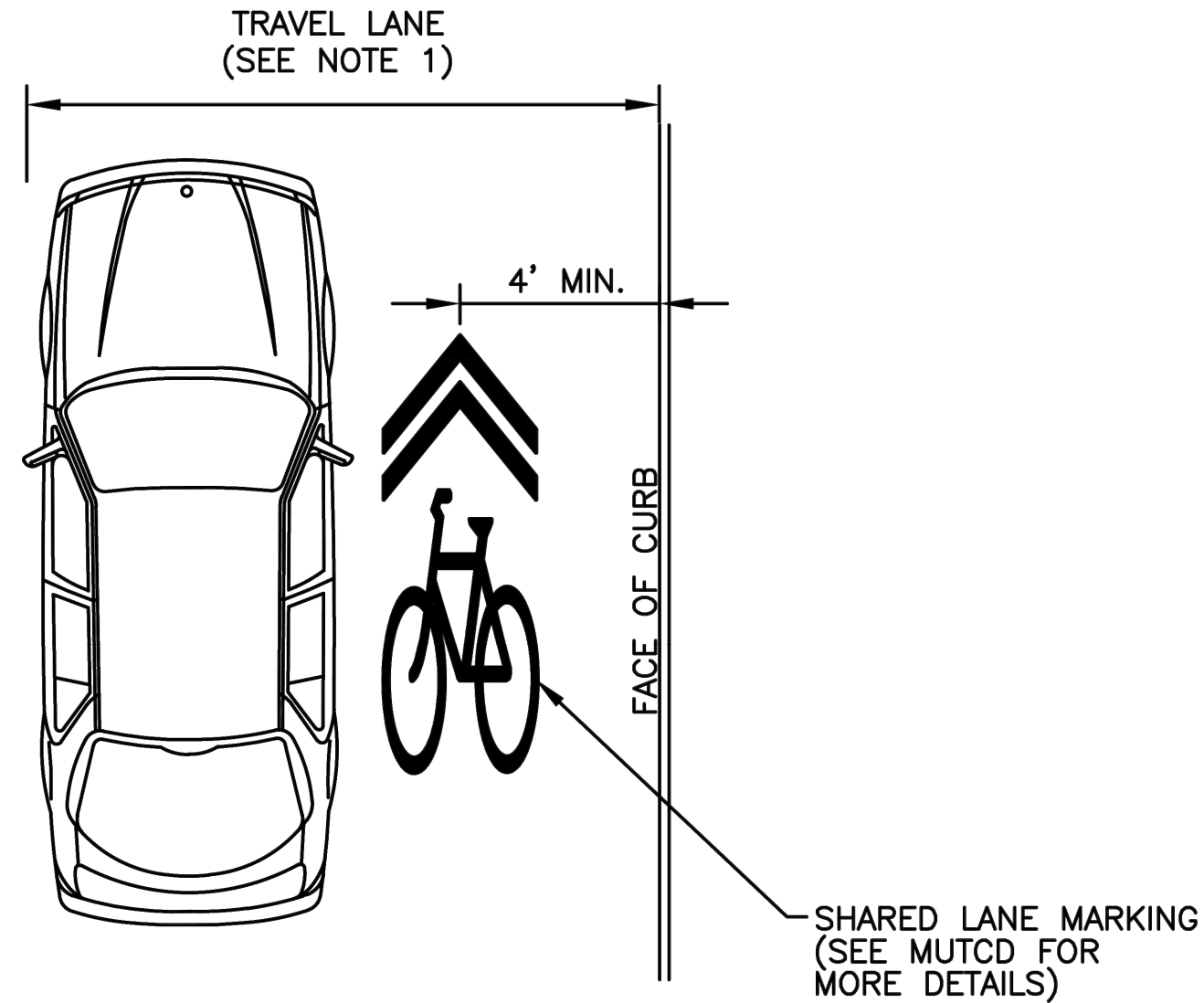

NOTES:

1. IF TRAVEL LANE IS LESS THAN 14' SHARED LANE MARKING SHALL BE CENTERED IN TRAVEL LANE.
2. DESIGN PLANS SHOULD BE CONSULTED FOR VARIATIONS.

TYPICAL SHARED LANE MARKINGS WITHOUT ADJACENT ON-STREET PARKING
N.T.S.

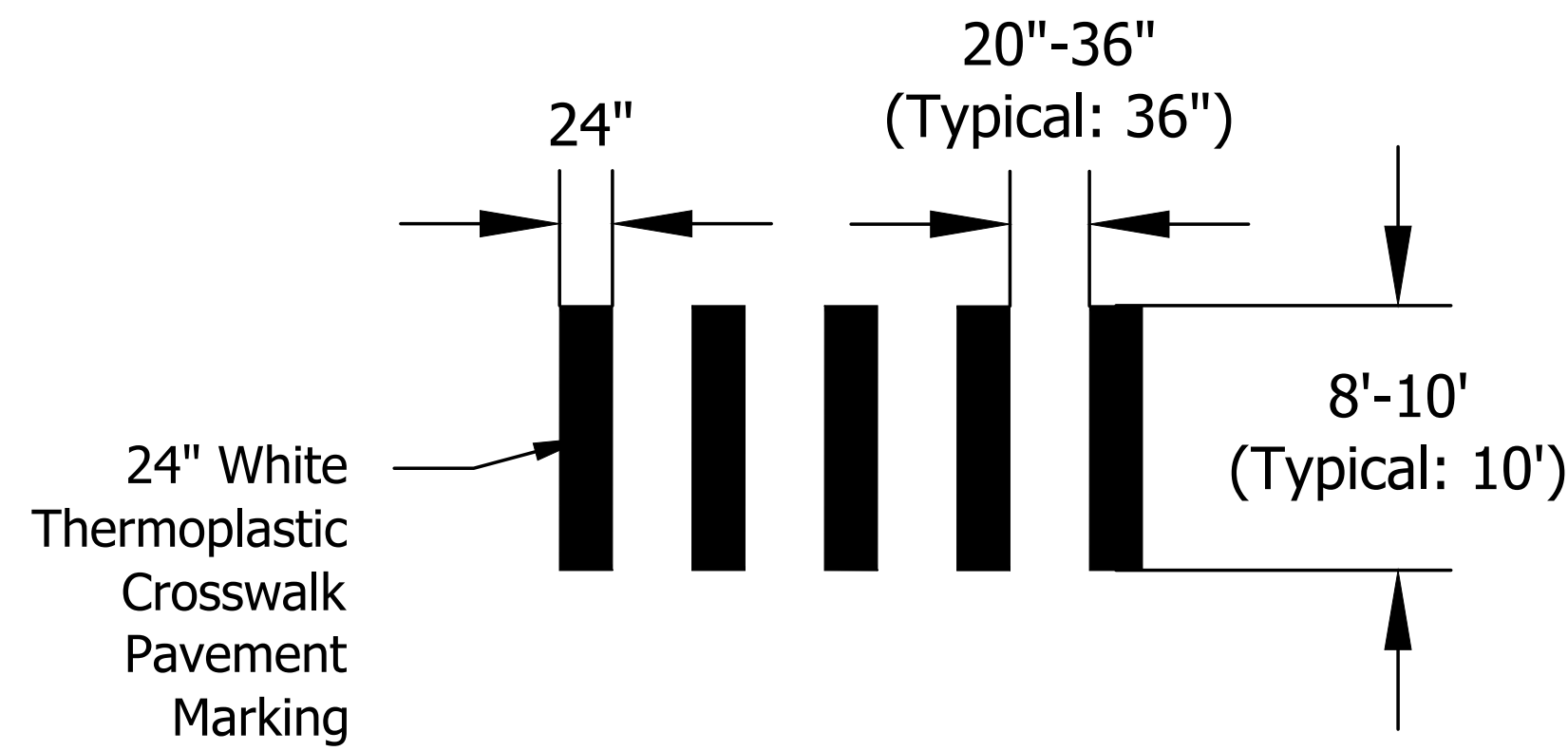

TYPICAL CROSSWALK
N.T.S.

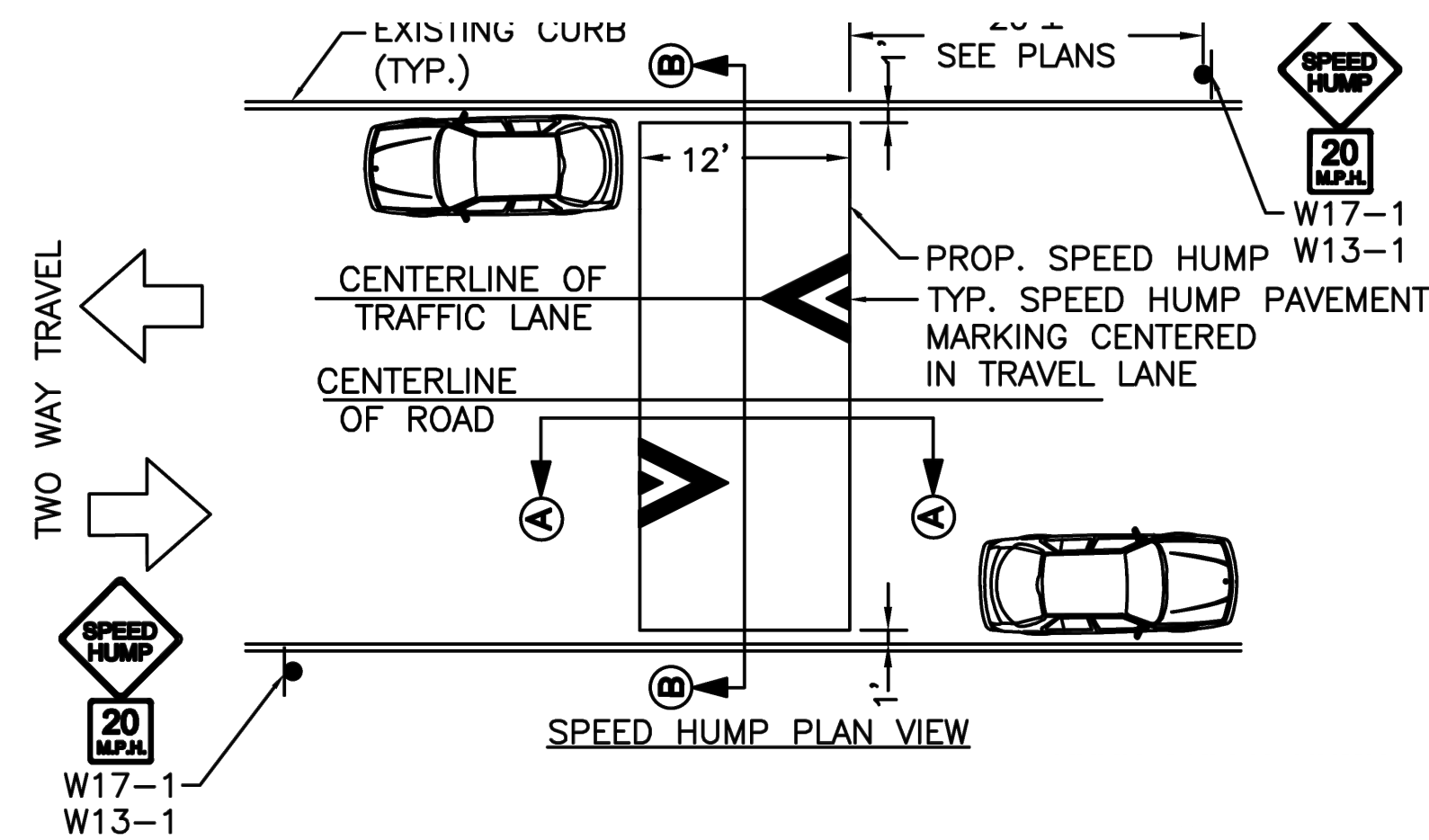

TYPICAL SPEED HUMP
N.T.S.

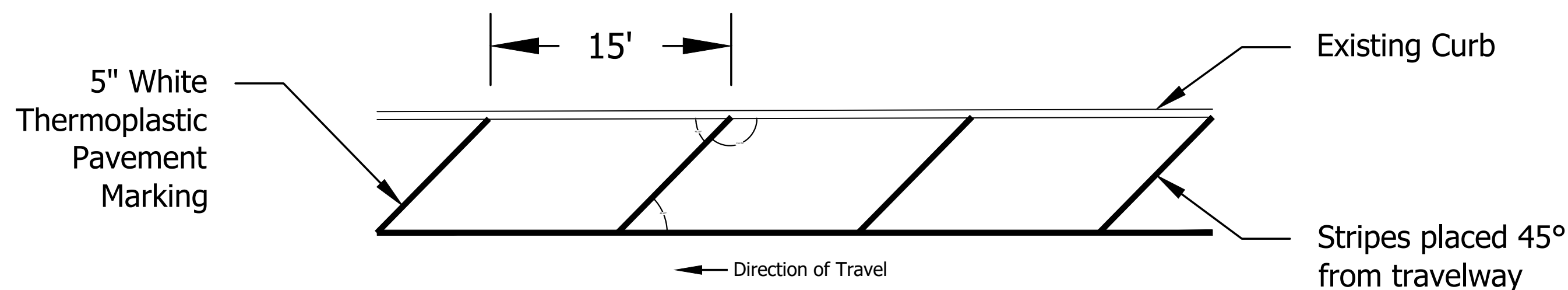

TYPICAL CURB EXTENSION GORE AREA
N.T.S.

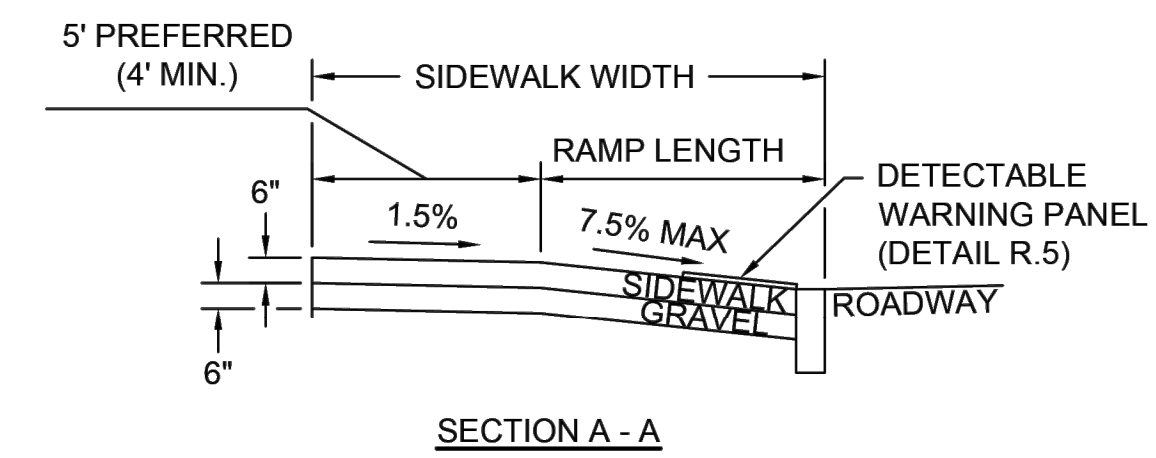
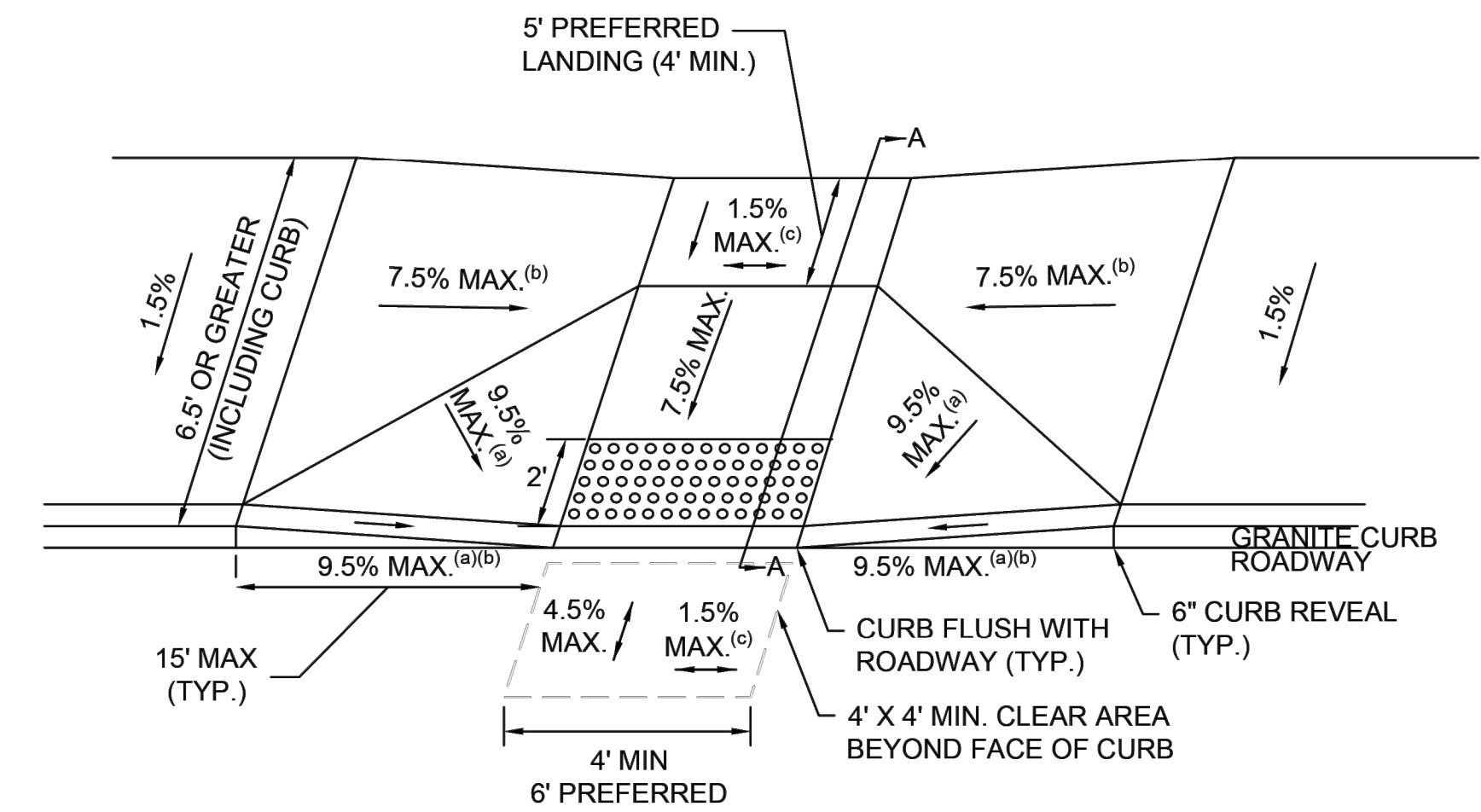

SECTION A - A

NOTES:

1. ^(a) 7.5% PREFERRED SLOPE.
2. ^(b) MAXIMUM SLOPE TRANSITION LENGTH MEASURED ALONG THE FACE OF CURB SHALL BE 15 FEET. A TRANSITION SLOPE GREATER THAN 9.5% IS ONLY ACCEPTABLE WHEN THE TRANSITION STONE REACHES A MAXIMUM LENGTH OF 15 FEET.
3. ^(c) THE LANDING CROSS SLOPE (PARALLEL TO THE CURB LINE) AND THE GUTTER RUNNING SLOPE SHALL BE A MAXIMUM OF 1.5% AT APPROACHES UNDER STOP OR YIELD CONTROL. THE SLOPE MAY EXCEED 1.5% MAXIMUM UNDER THE FOLLOWING CONDITIONS:
 - SIGNAL OR PEDESTRIAN HYBRID BEACON = 4.5% MAX.
 - UNCONTROLLED = 4.5% MAX.
 - MIDBLOCK = NO GREATER THAN STREET GRADE
 - ROUNDABOUT = NO GREATER THAN STREET GRADE
4. ± 0.5% MAX. CONSTRUCTION TOLERANCE PERMITTED ON ALL SLOPES.

PEDESTRIAN RAMP
N.T.S.

#	DATE	REVISION	APP'D

Submission Date:
6/30/2026

Drawn: EAA
Designed: EAA
Checked: CKM

PROJECT NO.
31213.003

ROLINS AVENUE COMPLETE STREET STUDY
CONSTRUCTION DETAILS

SHEET NO.
D-01

PRELIMINARY
NOT FOR
CONSTRUCTION

Plot Stamp: 6/30/2026 10:38:30 AM - Erika Adams
 File: H:\31\31219 - MCOG TLC and RSP On-Call\003 - Rollins-Twinbrook Complete Street Study\design_CD\31219.003-CD-SSPLAN-ALT 2.dwg

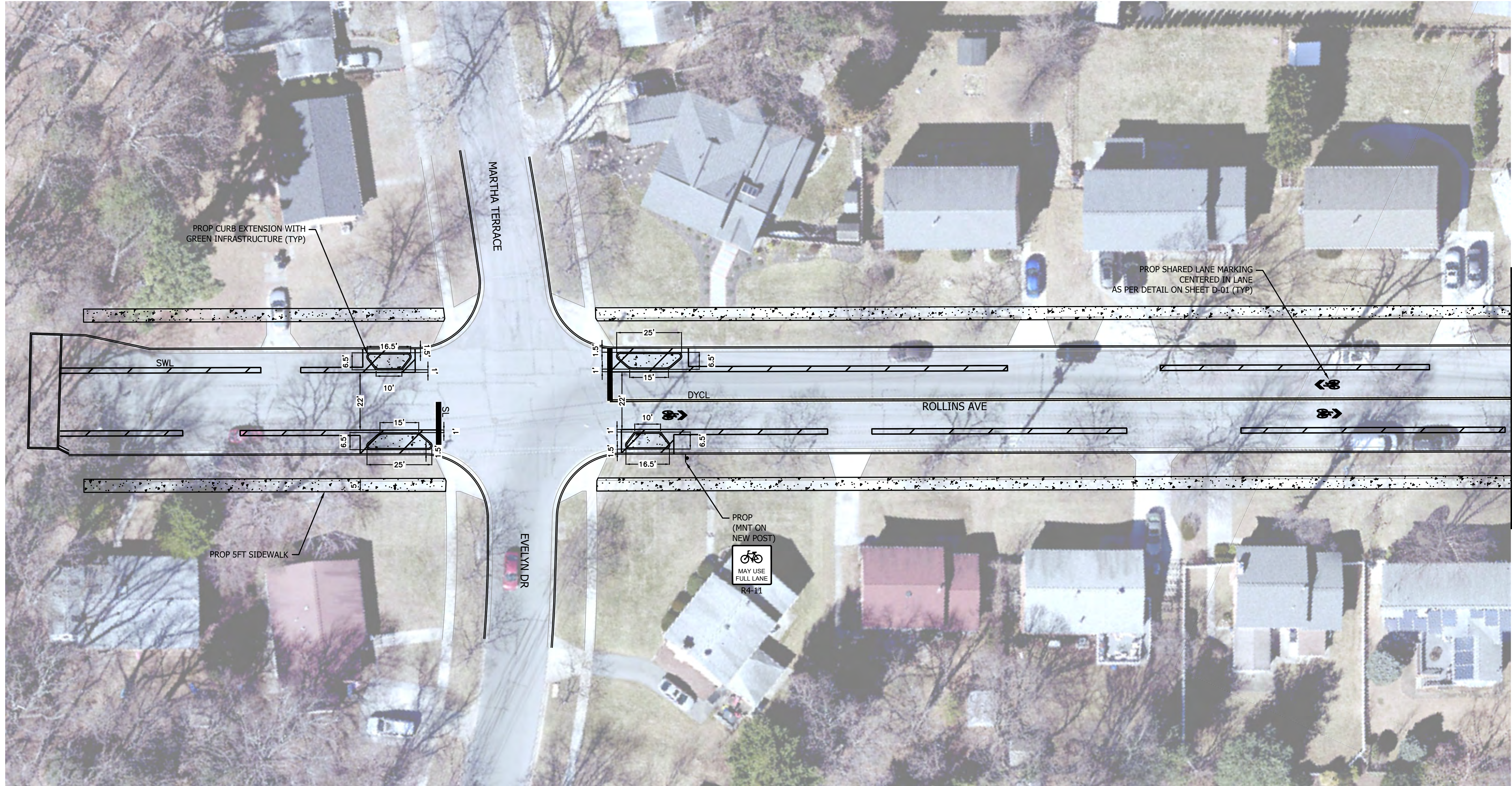

FOR CONTINUATION SEE SHEET SS-02

PRELIMINARY
 NOT FOR
 CONSTRUCTION

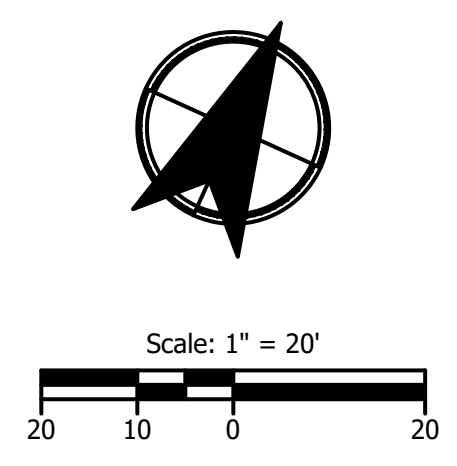

KITTELSON & ASSOCIATES
 100 M STREET SE, SUITE 910
 WASHINGTON, DC 20003
 P 202.450.3710

#	DATE	REVISION	APP'D

Submission Date:
 6/30/2026
 Drawn: EAA Designed: EAA Checked: CKM

PROJECT NO.
31213.003

ROLINS AVENUE COMPLETE STREET STUDY

SIGNING & STRIPING PLAN ALT 2

SHEET NO.
SS-01

Plot Stamp: 6/30/2026 10:38:34 AM - Erika Adams
 File: H:\31\31219 - MWCOC TLC and RSP On-Call\003 - Rollins-Twinbrook Complete Street Study\Design_CD\31219.003-CD-SSPLAN-ALT 2.dwg

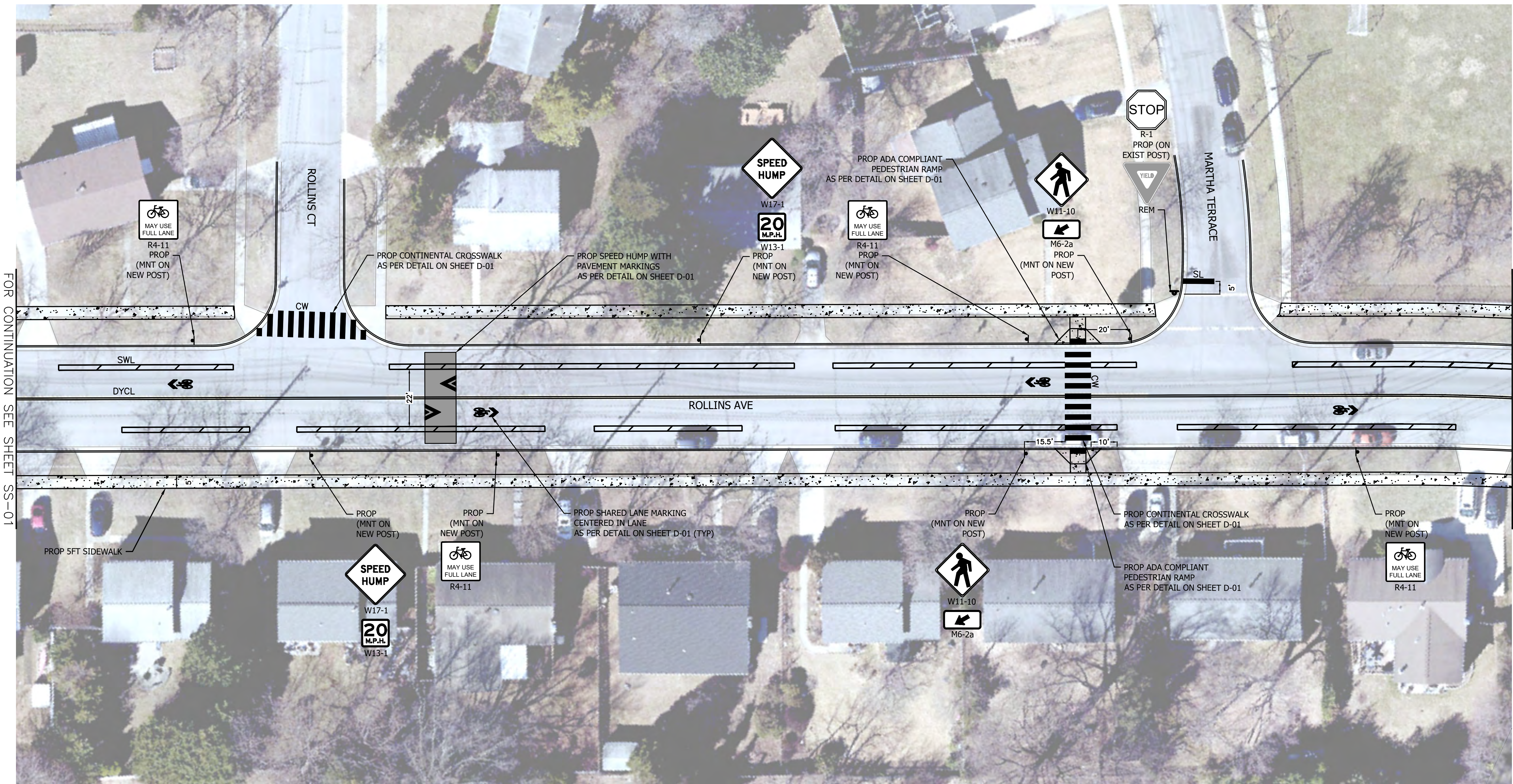

FOR CONTINUATION SEE SHEET SS-01

FOR CONTINUATION SEE SHEET SS-03

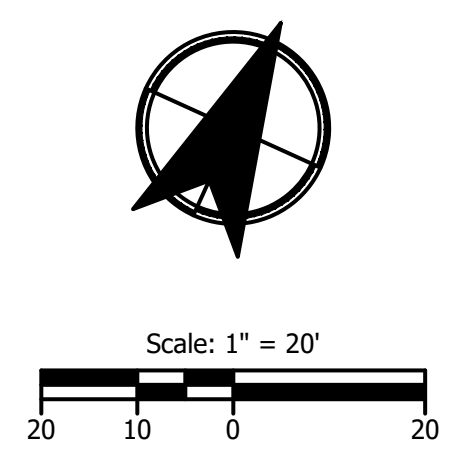

PRELIMINARY
 NOT FOR
 CONSTRUCTION



KITTELSON & ASSOCIATES
 100 M STREET SE, SUITE 910
 WASHINGTON, DC 20003
 P 202.450.3710

#	DATE	REVISION	APP'D

Submission Date:
 6/30/2026
 Drawn: EAA Designed: EAA Checked: CKM

PROJECT NO.
 31213.003

ROLINS AVENUE COMPLETE STREET STUDY
 SIGNING & STRIPING PLAN ALT 2

SHEET NO.
 SS-02

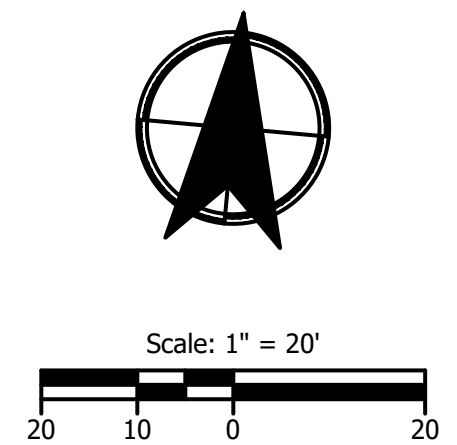
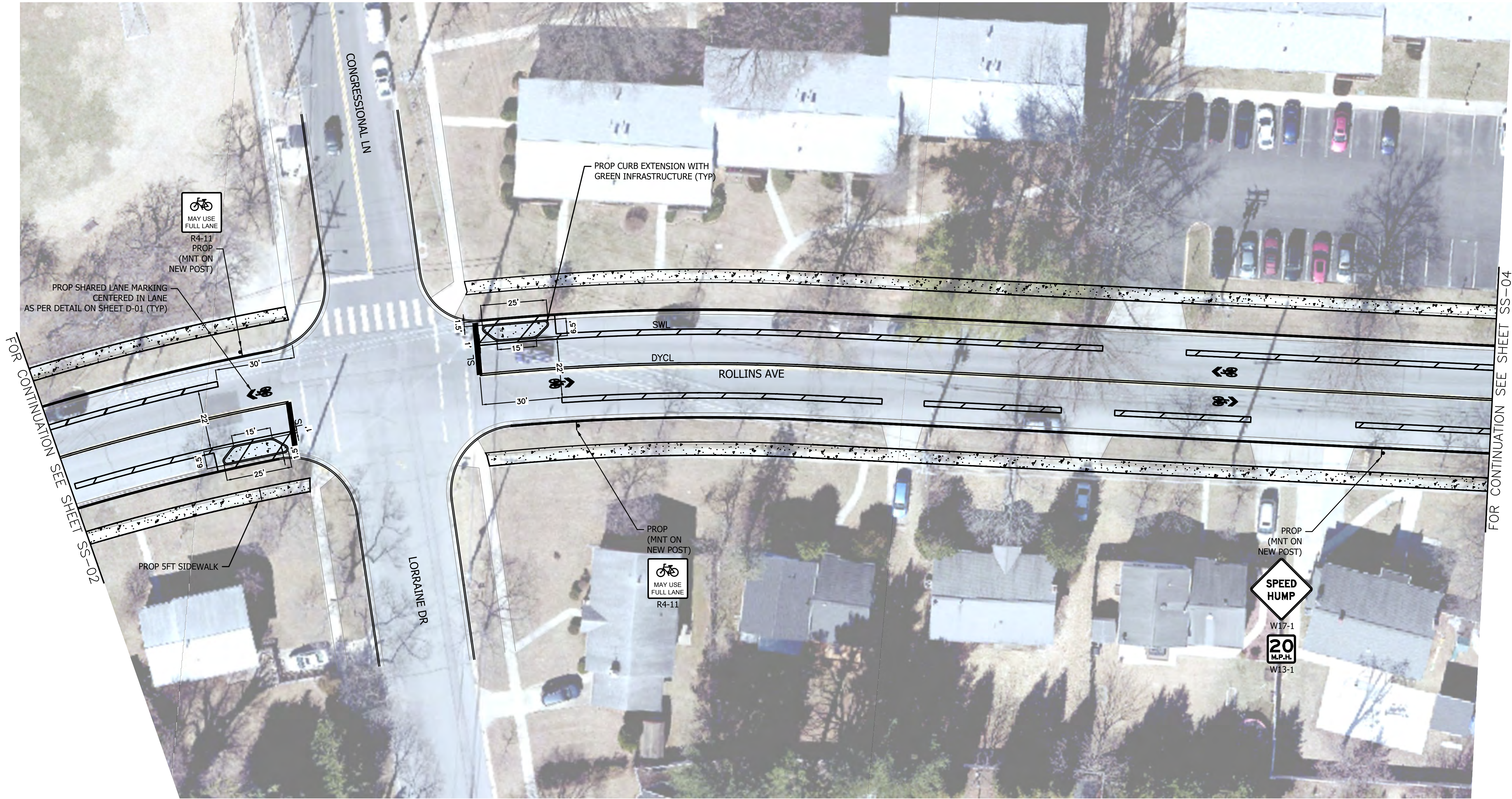

PRELIMINARY
 NOT FOR
 CONSTRUCTION

#	DATE	REVISION	APP'D

Submission Date:
 6/30/2026
 Drawn: EAA Designed: EAA Checked: CKM

PROJECT NO.
 31213.003

ROLLINS AVENUE COMPLETE STREET STUDY
 SIGNING & STRIPING PLAN ALT 2

SHEET NO.
 SS-03

Plot Stamp: 6/30/2026 10:38:39 AM - Erika Adams
 File: H:\31\31219 - MCOG TLC and RSP On-Call\003 - Rollins-Twinbrook Complete Street Study\design_CD\31219.003-CD-SSPLAN-ALT 2.dwg

FOR CONTINUATION SEE SHEET SS-03



FOR CONTINUATION SEE SHEET SS-05

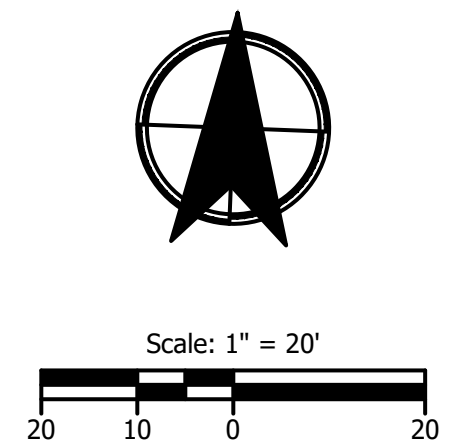

PRELIMINARY
 NOT FOR
 CONSTRUCTION



KITTELSON & ASSOCIATES
 100 M STREET SE, SUITE 910
 WASHINGTON, DC 20003
 P 202.450.3710

#	DATE	REVISION	APP'D

Submission Date:
 6/30/2026
 Drawn: EAA Designed: EAA Checked: CKM

PROJECT NO.
 31213.003

ROLINS AVENUE COMPLETE STREET STUDY
 SIGNING & STRIPING PLAN ALT 2

SHEET NO.
 SS-04

Plot Stamp: 6/30/2026 10:38:41 AM - Erika Adams
 File: H:\31\31219 - MCOG TLC and RSP On-Call\003 - Rollins-Twinbrook Complete Street Study\design_CD\31219.003-CD-SSPLAN-ALT 2.dwg

FOR CONTINUATION SEE SHEET SS-04

FOR CONTINUATION SEE SHEET SS-06

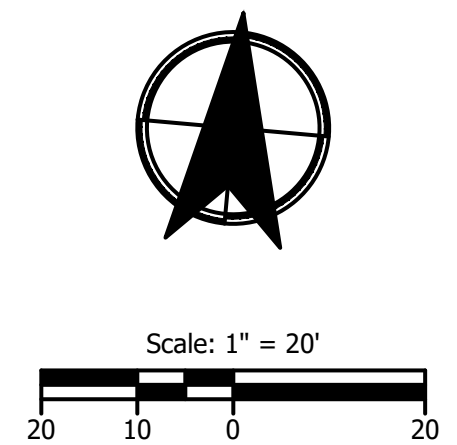

PRELIMINARY
 NOT FOR
 CONSTRUCTION



KITTELSON & ASSOCIATES
 100 M STREET SE, SUITE 910
 WASHINGTON, DC 20003
 P 202.450.3710

#	DATE	REVISION	APP'D

Submission Date: 6/30/2026
 Drawn: EAA Designed: EAA Checked: CKM
 PROJECT NO. 31213.003

ROLLINS AVENUE COMPLETE STREET STUDY
 SIGNING & STRIPING PLAN ALT 2

SHEET NO. SS-05

Plot Stamp: 6/30/2026 10:38:44 AM - Erika Adams
 File: H:\31\31219 - MCOG TLC and RSP On-Call\003 - Rollins-Twinbrook Complete Street Study\design_CD\31219.003-CD-SSPLAN-ALT 2.dwg

FOR CONTINUATION SEE SHEET SS-05



FOR CONTINUATION SEE SHEET SS-07

PRELIMINARY
 NOT FOR
 CONSTRUCTION

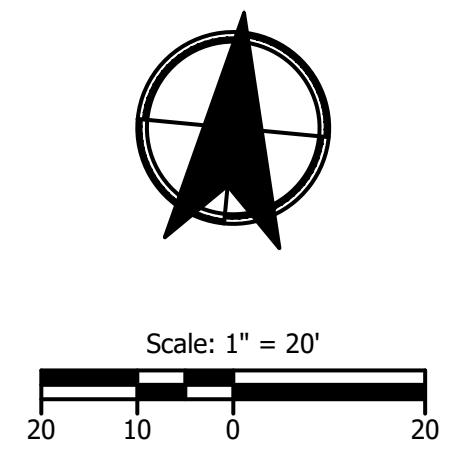

KITTELSON & ASSOCIATES
 100 M STREET SE, SUITE 910
 WASHINGTON, DC 20003
 P 202.450.3710

#	DATE	REVISION	APP'D

Submission Date:
 6/30/2026
 Drawn: EAA Designed: EAA Checked: CKM

PROJECT NO.
 31213.003

ROLLINS AVENUE COMPLETE STREET STUDY
 SIGNING & STRIPING PLAN ALT 2

SHEET NO.
 SS-06

FOR CONTINUATION SEE SHEET SS-06

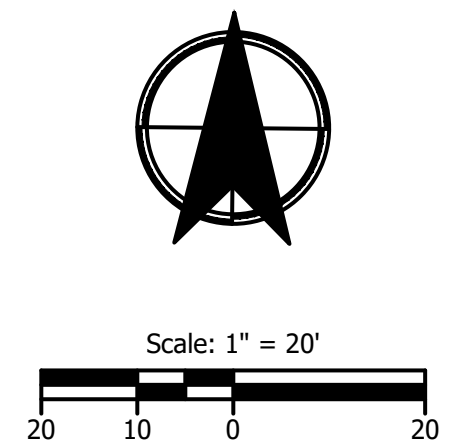
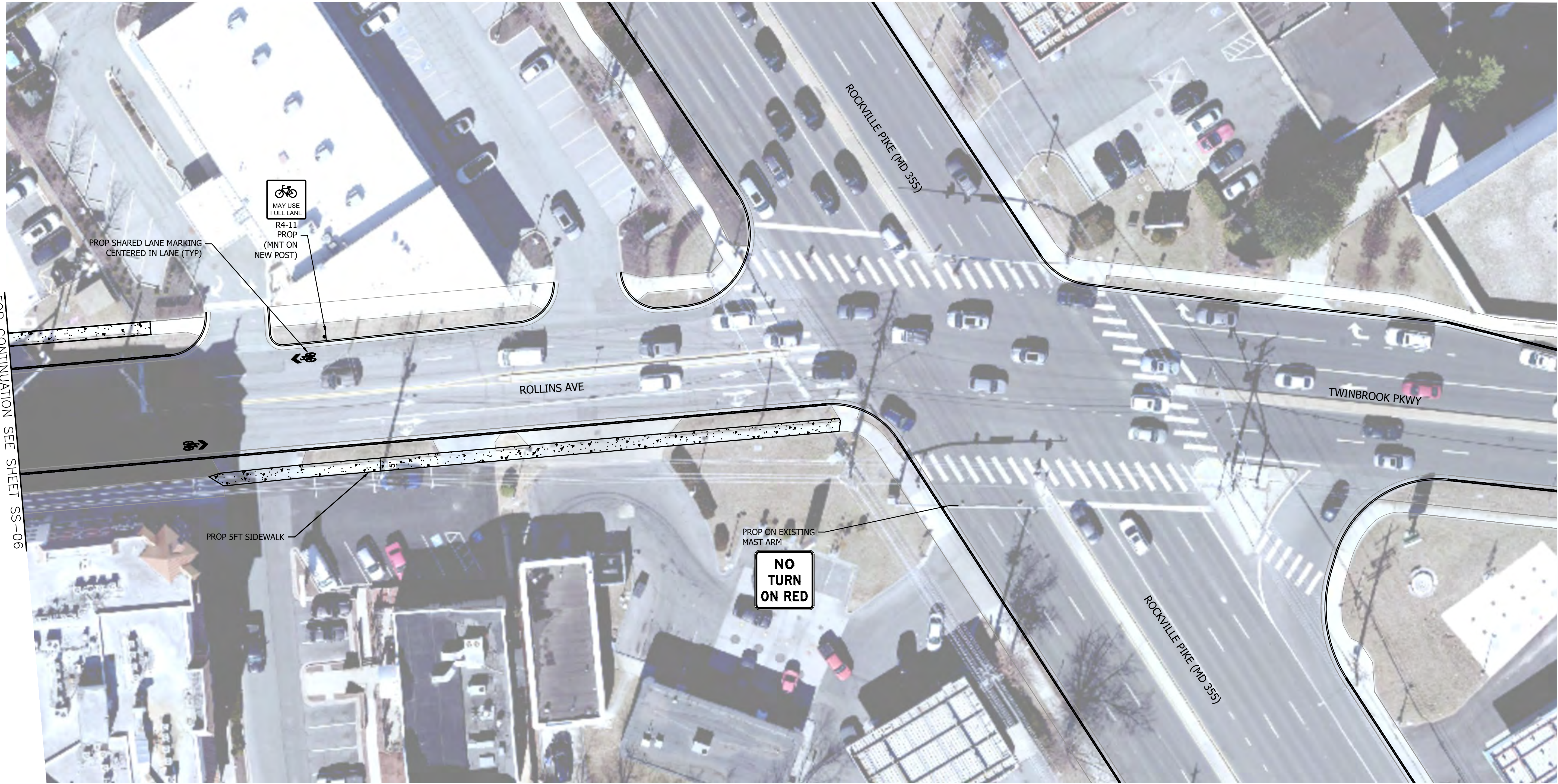

PRELIMINARY
 NOT FOR
 CONSTRUCTION

#	DATE	REVISION	APP'D







Submission Date:
 6/30/2026
 Drawn: EAA Designed: EAA Checked: CKM

PROJECT NO.
31213.003

ROLINS AVENUE COMPLETE STREET STUDY

SIGNING & STRIPING PLAN ALT 2

SHEET NO.
SS-07

IDENTIFICATION NUMBER	SIZE OF SIGN (INCHES)		UNIT AREA SF	TEXT	TEXT DIMENSIONS	NUMBER OF SIGNS REQUIRED	COLOR	POST SIZE AND NUMBER REQUIRED PER SIGN	AREA IN SQUARE FEET
	WIDTH	HEIGHT							
R-1	30"	30"	6.25		SEE MUTCD STANDARD DETAIL	1	SEE MUTCD STANDARD DETAIL	MNT ON EXIST 2" POST	6.25
W11-2	30"	30"	6.25			4		MNT ON 2" POST (2)	25.00
M6-2a	24"	12"	2			4		MNT BENEATH W11-2	8.00
R14-11	30"	30"	6.25	 MAY USE FULL LANE		10		MNT ON 2" POST (10)	62.50
W17-1	30"	30"	6.25			4		MNT ON 2" POST (4)	25.00
W13-1	18"	18"	2.25			4		MNT BENEATH W17-1	9.00
R10-11b	30"	30"	6.25			1		MNT ON EXIST MAST ARM	6.25

PRELIMINARY
 NOT FOR
 CONSTRUCTION



KITTELSON & ASSOCIATES
 100 M STREET SE, SUITE 910
 WASHINGTON, DC 20003
 P 202.450.3710

#	DATE	REVISION	APP'D

Submission Date:
 6/30/2026

Drawn: EAA	Designed: EAA	Checked: CKM
---------------	------------------	-----------------

PROJECT NO.
 31213.003

ROLINS AVENUE COMPLETE STREET STUDY
 SIGNING & STRIPING PLAN ALT 2

SHEET NO.
 SS-08

APPENDIX E BUILD SYNCHRO OUTPUT REPORTS

Queues
3: East Jefferson St & Rollins Ave

Alternative 1
Timing Plan: AM Peak

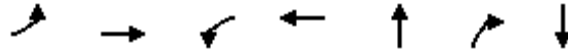





















Lane Group	EBL	EBT	WBL	WBT	NBT	NBR	SBT
Lane Group Flow (vph)	10	21	172	167	392	334	256
v/c Ratio	0.10	0.19	0.76	0.76	0.53	0.37	0.39
Control Delay	36.8	22.5	54.1	50.0	24.2	8.6	30.6
Queue Delay	0.0	0.0	0.0	0.0	0.0	0.0	0.0
Total Delay	36.8	22.5	54.1	50.0	24.2	8.6	30.6
Queue Length 50th (ft)	5	2	87	72	131	62	59
Queue Length 95th (ft)	18	21	#153	#147	#276	96	92
Internal Link Dist (ft)		1000		777	823		684
Turn Bay Length (ft)			250				
Base Capacity (vph)	171	184	273	260	741	908	651
Starvation Cap Reductn	0	0	0	0	0	0	0
Spillback Cap Reductn	0	0	0	0	0	0	0
Storage Cap Reductn	0	0	0	0	0	0	0
Reduced v/c Ratio	0.06	0.11	0.63	0.64	0.53	0.37	0.39

Intersection Summary

95th percentile volume exceeds capacity, queue may be longer.
Queue shown is maximum after two cycles.

HCM Signalized Intersection Capacity Analysis
3: East Jefferson St & Rollins Ave

Alternative 1
Timing Plan: AM Peak

													
Movement	EBL	EBT	EBR	WBL	WBT	WBR	NBL	NBT	NBR	SBL	SBT	SBR	
Lane Configurations													
Traffic Volume (vph)	8	3	14	237	17	45	12	329	291	13	201	11	
Future Volume (vph)	8	3	14	237	17	45	12	329	291	13	201	11	
Ideal Flow (vphpl)	1900	1900	1900	1900	1900	1900	1900	1900	1900	1900	1900	1900	
Total Lost time (s)	5.5	5.5		5.0	5.0			6.0	6.0		6.0		
Lane Util. Factor	1.00	1.00		0.95	0.95			1.00	1.00		0.95		
Frt	1.00	0.88		1.00	0.95			1.00	0.85		0.99		
Flt Protected	0.95	1.00		0.95	0.97			1.00	1.00		1.00		
Satd. Flow (prot)	1444	1427		1681	1480			1826	1583		3479		
Flt Permitted	0.95	1.00		0.95	0.97			1.00	1.00		1.00		
Satd. Flow (perm)	1444	1427		1681	1480			1826	1583		3479		
Peak-hour factor, PHF	0.83	0.83	0.83	0.88	0.88	0.88	0.87	0.87	0.87	0.88	0.88	0.88	
Adj. Flow (vph)	10	4	17	269	19	51	14	378	334	15	228	12	
RTOR Reduction (vph)	0	16	0	0	21	0	0	0	0	0	0	0	
Lane Group Flow (vph)	10	5	0	172	146	0	0	392	334	0	256	0	
Heavy Vehicles (%)	25%	0%	21%	2%	0%	2%	0%	4%	2%	0%	3%	0%	
Parking (#/hr)					0								
Turn Type	Split	NA		Split	NA		Split	NA	pt+ov	Split	NA		
Protected Phases	4	4		3	3		2	2	2 3	6	6		
Permitted Phases													
Actuated Green, G (s)	2.5	2.5		10.8	10.8			29.2	40.0		15.0		
Effective Green, g (s)	2.5	2.5		10.8	10.8			29.2	40.0		15.0		
Actuated g/C Ratio	0.03	0.03		0.14	0.14			0.36	0.50		0.19		
Clearance Time (s)	5.5	5.5		5.0	5.0			6.0			6.0		
Vehicle Extension (s)	2.0	2.0		1.0	1.0			5.0			5.0		
Lane Grp Cap (vph)	45	44		226	199			666	791		652		
v/s Ratio Prot	c0.01	0.00		c0.10	0.10			c0.21	0.21		c0.07		
v/s Ratio Perm													
v/c Ratio	0.22	0.10		0.76	0.73			0.59	0.42		0.39		
Uniform Delay, d1	37.8	37.7		33.4	33.2			20.5	12.7		28.5		
Progression Factor	1.00	1.00		1.00	1.00			1.00	1.00		1.00		
Incremental Delay, d2	0.9	0.4		12.7	11.4			3.8	0.1		0.8		
Delay (s)	38.7	38.0		46.1	44.7			24.3	12.8		29.3		
Level of Service	D	D		D	D			C	B		C		
Approach Delay (s)		38.3			45.4			19.0			29.3		
Approach LOS		D			D			B			C		
Intersection Summary													
HCM 2000 Control Delay			28.0									HCM 2000 Level of Service	C
HCM 2000 Volume to Capacity ratio			0.55										
Actuated Cycle Length (s)			80.0									Sum of lost time (s)	22.5
Intersection Capacity Utilization			51.2%									ICU Level of Service	A
Analysis Period (min)			15										

c Critical Lane Group

Queues
5: Rockville Pike & Twinbrook Pkwy

Alternative 1
Timing Plan: AM Peak



Lane Group	EBT	WBT	WBR	NBL	NBT	NBR	SBL	SBT
Lane Group Flow (vph)	336	375	186	108	1089	162	164	1251
v/c Ratio	0.58	0.63	0.68	0.33	0.35	0.16	0.43	0.39
Control Delay	60.5	61.8	70.3	9.8	14.8	2.5	10.3	14.6
Queue Delay	0.0	0.0	0.0	0.0	0.0	0.0	0.0	0.0
Total Delay	60.5	61.8	70.3	9.8	14.8	2.5	10.3	14.6
Queue Length 50th (ft)	161	182	173	27	176	0	42	204
Queue Length 95th (ft)	200	204	224	57	257	35	83	292
Internal Link Dist (ft)	203	744			712			906
Turn Bay Length (ft)			100	150		290	350	
Base Capacity (vph)	835	861	392	425	3119	1013	465	3181
Starvation Cap Reductn	0	0	0	0	0	0	0	0
Spillback Cap Reductn	0	0	0	0	0	0	0	0
Storage Cap Reductn	0	0	0	0	0	0	0	0
Reduced v/c Ratio	0.40	0.44	0.47	0.25	0.35	0.16	0.35	0.39
Intersection Summary								

HCM Signalized Intersection Capacity Analysis

5: Rockville Pike & Twinbrook Pkwy

Alternative 1
Timing Plan: AM Peak



Movement	EBL	EBT	EBR	WBL	WBT	WBR	NBU	NBL	NBT	NBR	SBU	SBL
Lane Configurations		↑↑			↑↑	↑			↑↑↑	↑		↑
Traffic Volume (vph)	0	243	90	0	315	156	27	71	991	147	11	150
Future Volume (vph)	0	243	90	0	315	156	27	71	991	147	11	150
Ideal Flow (vphpl)	1900	1900	1900	1900	1900	1900	1900	1900	1900	1900	1900	1900
Total Lost time (s)		7.5			7.5	7.5		7.0	5.5	5.5		7.0
Lane Util. Factor		0.95			0.95	1.00		1.00	0.91	1.00		1.00
Frt		0.96			1.00	0.85		1.00	1.00	0.85		1.00
Flt Protected		1.00			1.00	1.00		0.95	1.00	1.00		0.95
Satd. Flow (prot)		3435			3539	1615		1785	4988	1524		1788
Flt Permitted		1.00			1.00	1.00		0.19	1.00	1.00		0.22
Satd. Flow (perm)		3435			3539	1615		348	4988	1524		411
Peak-hour factor, PHF	0.99	0.99	0.99	0.84	0.84	0.84	0.91	0.91	0.91	0.91	0.98	0.98
Adj. Flow (vph)	0	245	91	0	375	186	30	78	1089	162	11	153
RTOR Reduction (vph)	0	0	0	0	0	0	0	0	0	61	0	0
Lane Group Flow (vph)	0	336	0	0	375	186	0	108	1089	101	0	164
Heavy Vehicles (%)	0%	0%	3%	0%	2%	0%	4%	0%	4%	6%	0%	1%
Turn Type		NA			NA	Perm	pm+pt	pm+pt	NA	Perm	pm+pt	pm+pt
Protected Phases		4			8		5	5	2		1	1
Permitted Phases						8	2	2		2	6	6
Actuated Green, G (s)		25.4			25.4	25.4		103.0	93.8	93.8		106.2
Effective Green, g (s)		25.4			25.4	25.4		103.0	93.8	93.8		106.2
Actuated g/C Ratio		0.17			0.17	0.17		0.69	0.63	0.63		0.71
Clearance Time (s)		7.5			7.5	7.5		7.0	5.5	5.5		7.0
Vehicle Extension (s)		4.0			4.0	4.0		4.0	0.2	0.2		4.0
Lane Grp Cap (vph)		581			599	273		327	3119	953		390
v/s Ratio Prot		0.10			0.11			0.02	0.22			c0.03
v/s Ratio Perm						c0.12		0.21		0.07		c0.27
v/c Ratio		0.58			0.63	0.68		0.33	0.35	0.11		0.42
Uniform Delay, d1		57.4			57.9	58.5		8.4	13.5	11.3		7.8
Progression Factor		1.00			1.00	1.00		1.00	1.00	1.00		1.00
Incremental Delay, d2		1.7			2.3	7.4		0.8	0.3	0.2		1.0
Delay (s)		59.0			60.2	65.9		9.3	13.8	11.5		8.8
Level of Service		E			E	E		A	B	B		A
Approach Delay (s)		59.0			62.1				13.1			
Approach LOS		E			E				B			

Intersection Summary

HCM 2000 Control Delay	24.8	HCM 2000 Level of Service	C
HCM 2000 Volume to Capacity ratio	0.48		
Actuated Cycle Length (s)	150.0	Sum of lost time (s)	20.0
Intersection Capacity Utilization	55.6%	ICU Level of Service	B
Analysis Period (min)	15		
c Critical Lane Group			

HCM Signalized Intersection Capacity Analysis
5: Rockville Pike & Twinbrook Pkwy

Alternative 1
Timing Plan: AM Peak



Movement	SBT	SBR
Lane Configurations	↑↑↑	↘
Traffic Volume (vph)	1161	65
Future Volume (vph)	1161	65
Ideal Flow (vphpl)	1900	1900
Total Lost time (s)	5.5	
Lane Util. Factor	0.91	
Frt	0.99	
Flt Protected	1.00	
Satd. Flow (prot)	5004	
Flt Permitted	1.00	
Satd. Flow (perm)	5004	
Peak-hour factor, PHF	0.98	0.98
Adj. Flow (vph)	1185	66
RTOR Reduction (vph)	0	0
Lane Group Flow (vph)	1251	0
Heavy Vehicles (%)	3%	0%
Turn Type	NA	
Protected Phases	6	
Permitted Phases		
Actuated Green, G (s)	95.4	
Effective Green, g (s)	95.4	
Actuated g/C Ratio	0.64	
Clearance Time (s)	5.5	
Vehicle Extension (s)	0.2	
Lane Grp Cap (vph)	3182	
v/s Ratio Prot	0.25	
v/s Ratio Perm		
v/c Ratio	0.39	
Uniform Delay, d1	13.3	
Progression Factor	1.00	
Incremental Delay, d2	0.4	
Delay (s)	13.6	
Level of Service	B	
Approach Delay (s)	13.1	
Approach LOS	B	
Intersection Summary		

Queues
3: East Jefferson St & Rollins Ave

Alternative 1
Timing Plan: PM Peak

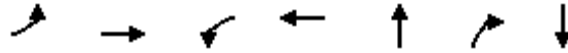





















Lane Group	EBL	EBT	WBL	WBT	NBT	NBR	SBT
Lane Group Flow (vph)	11	92	294	289	501	447	485
v/c Ratio	0.10	0.56	0.81	0.87	0.84	0.52	0.88
Control Delay	38.9	43.8	51.1	57.3	47.0	10.6	56.0
Queue Delay	0.0	0.0	0.0	0.0	0.0	0.0	0.0
Total Delay	38.9	43.8	51.1	57.3	47.0	10.6	56.0
Queue Length 50th (ft)	6	39	165	156	280	86	143
Queue Length 95th (ft)	15	54	252	#268	#530	134	#225
Internal Link Dist (ft)		1000		777	823		684
Turn Bay Length (ft)			250				
Base Capacity (vph)	133	195	438	400	596	853	552
Starvation Cap Reductn	0	0	0	0	0	0	0
Spillback Cap Reductn	0	0	0	0	0	0	0
Storage Cap Reductn	0	0	0	0	0	0	0
Reduced v/c Ratio	0.08	0.47	0.67	0.72	0.84	0.52	0.88

Intersection Summary

95th percentile volume exceeds capacity, queue may be longer.
Queue shown is maximum after two cycles.

HCM Signalized Intersection Capacity Analysis
3: East Jefferson St & Rollins Ave

Alternative 1
Timing Plan: PM Peak

													
Movement	EBL	EBT	EBR	WBL	WBT	WBR	NBL	NBT	NBR	SBL	SBT	SBR	
Lane Configurations													
Traffic Volume (vph)	7	39	19	425	63	60	2	479	429	29	388	14	
Future Volume (vph)	7	39	19	425	63	60	2	479	429	29	388	14	
Ideal Flow (vphpl)	1900	1900	1900	1900	1900	1900	1900	1900	1900	1900	1900	1900	
Total Lost time (s)	5.5	5.5		5.0	5.0			6.0	6.0		6.0		
Lane Util. Factor	1.00	1.00		0.95	0.95			1.00	1.00		0.95		
Frt	1.00	0.95		1.00	0.97			1.00	0.85		1.00		
Flt Protected	0.95	1.00		0.95	0.97			1.00	1.00		1.00		
Satd. Flow (prot)	1262	1666		1715	1522			1863	1599		3548		
Flt Permitted	0.95	1.00		0.95	0.97			1.00	1.00		1.00		
Satd. Flow (perm)	1262	1666		1715	1522			1863	1599		3548		
Peak-hour factor, PHF	0.63	0.63	0.63	0.94	0.94	0.94	0.96	0.96	0.96	0.89	0.89	0.89	
Adj. Flow (vph)	11	62	30	452	67	64	2	499	447	33	436	16	
RTOR Reduction (vph)	0	20	0	0	12	0	0	0	0	0	0	0	
Lane Group Flow (vph)	11	72	0	294	277	0	0	501	447	0	485	0	
Heavy Vehicles (%)	43%	0%	26%	0%	0%	2%	0%	2%	1%	0%	1%	0%	
Parking (#/hr)					0								
Turn Type	Split	NA		Split	NA		Split	NA	pt+ov	Split	NA		
Protected Phases	4	4		3	3		2	2	2 3	6	6		
Permitted Phases													
Actuated Green, G (s)	6.7	6.7		19.0	19.0			27.8	46.8		14.0		
Effective Green, g (s)	6.7	6.7		19.0	19.0			27.8	46.8		14.0		
Actuated g/C Ratio	0.07	0.07		0.21	0.21			0.31	0.52		0.16		
Clearance Time (s)	5.5	5.5		5.0	5.0			6.0			6.0		
Vehicle Extension (s)	2.0	2.0		1.0	1.0			5.0			5.0		
Lane Grp Cap (vph)	93	124		362	321			575	831		551		
v/s Ratio Prot	0.01	c0.04		0.17	c0.18			c0.27	0.28		c0.14		
v/s Ratio Perm													
v/c Ratio	0.12	0.58		0.81	0.86			0.87	0.54		0.88		
Uniform Delay, d1	38.9	40.3		33.8	34.2			29.4	14.4		37.2		
Progression Factor	1.00	1.00		1.00	1.00			1.00	1.00		1.00		
Incremental Delay, d2	0.2	4.0		12.3	20.0			16.5	0.3		16.2		
Delay (s)	39.1	44.3		46.1	54.3			45.9	14.7		53.4		
Level of Service	D	D		D	D			D	B		D		
Approach Delay (s)		43.7			50.2			31.2			53.4		
Approach LOS		D			D			C			D		
Intersection Summary													
HCM 2000 Control Delay			42.1									HCM 2000 Level of Service	D
HCM 2000 Volume to Capacity ratio			0.84										
Actuated Cycle Length (s)			90.0									Sum of lost time (s)	22.5
Intersection Capacity Utilization			64.3%									ICU Level of Service	C
Analysis Period (min)			15										

c Critical Lane Group

Queues
5: Rockville Pike & Twinbrook Pkwy

Alternative 1
Timing Plan: PM Peak



Lane Group	EBT	WBT	WBR	NBL	NBT	NBR	SBL	SBT
Lane Group Flow (vph)	592	540	229	118	1565	238	279	1493
v/c Ratio	0.78	0.69	0.66	0.46	0.60	0.27	0.81	0.50
Control Delay	63.2	58.9	63.2	16.8	28.0	12.3	50.1	20.1
Queue Delay	0.0	0.0	0.0	0.0	0.0	0.0	0.0	0.0
Total Delay	63.2	58.9	63.2	16.8	28.0	12.3	50.1	20.1
Queue Length 50th (ft)	288	257	206	36	405	65	170	304
Queue Length 95th (ft)	349	314	294	64	473	129	#307	395
Internal Link Dist (ft)	203	744			712			906
Turn Bay Length (ft)			100	150		290	350	
Base Capacity (vph)	851	878	389	405	2618	880	365	2966
Starvation Cap Reductn	0	0	0	0	0	0	0	0
Spillback Cap Reductn	0	0	0	0	0	0	0	0
Storage Cap Reductn	0	0	0	0	0	0	0	0
Reduced v/c Ratio	0.70	0.62	0.59	0.29	0.60	0.27	0.76	0.50













Intersection Summary

95th percentile volume exceeds capacity, queue may be longer.
Queue shown is maximum after two cycles.

HCM Signalized Intersection Capacity Analysis

5: Rockville Pike & Twinbrook Pkwy

Alternative 1
Timing Plan: PM Peak

												
Movement	EBL	EBT	EBR	WBL	WBT	WBR	NBU	NBL	NBT	NBR	SBU	SBL
Lane Configurations		↑↑			↑↑	↑			↑↑↑	↑		↑
Traffic Volume (vph)	0	430	103	0	497	211	26	87	1502	228	5	249
Future Volume (vph)	0	430	103	0	497	211	26	87	1502	228	5	249
Ideal Flow (vphpl)	1900	1900	1900	1900	1900	1900	1900	1900	1900	1900	1900	1900
Total Lost time (s)		7.5			7.5	7.5		7.0	5.5	5.5		7.0
Lane Util. Factor		0.95			0.95	1.00		1.00	0.91	1.00		1.00
Frt		0.97			1.00	0.85		1.00	1.00	0.85		1.00
Flt Protected		1.00			1.00	1.00		0.95	1.00	1.00		0.95
Satd. Flow (prot)		3499			3610	1599		1791	5136	1615		1805
Flt Permitted		1.00			1.00	1.00		0.14	1.00	1.00		0.09
Satd. Flow (perm)		3499			3610	1599		262	5136	1615		164
Peak-hour factor, PHF	0.90	0.90	0.90	0.92	0.92	0.92	0.96	0.96	0.96	0.96	0.91	0.91
Adj. Flow (vph)	0	478	114	0	540	229	27	91	1565	238	5	274
RTOR Reduction (vph)	0	0	0	0	0	0	0	0	0	56	0	0
Lane Group Flow (vph)	0	592	0	0	540	229	0	118	1565	182	0	279
Heavy Vehicles (%)	0%	0%	1%	0%	0%	1%	0%	1%	1%	0%	0%	0%
Turn Type		NA			NA	Perm	pm+pt	pm+pt	NA	Perm	pm+pt	pm+pt
Protected Phases		4			8		5	5	2		1	1
Permitted Phases						8	2	2		2	6	6
Actuated Green, G (s)		32.4			32.4	32.4		87.0	76.5	76.5		104.6
Effective Green, g (s)		32.4			32.4	32.4		87.0	76.5	76.5		104.6
Actuated g/C Ratio		0.22			0.22	0.22		0.58	0.51	0.51		0.70
Clearance Time (s)		7.5			7.5	7.5		7.0	5.5	5.5		7.0
Vehicle Extension (s)		4.0			4.0	4.0		4.0	0.2	0.2		4.0
Lane Grp Cap (vph)		755			779	345		258	2619	823		345
v/s Ratio Prot		c0.17			0.15			0.03	0.30			c0.11
v/s Ratio Perm						0.14		0.23		0.11		c0.45
v/c Ratio		0.78			0.69	0.66		0.46	0.60	0.22		0.81
Uniform Delay, d1		55.5			54.2	53.8		14.9	25.9	20.3		36.6
Progression Factor		1.00			1.00	1.00		1.00	1.00	1.00		1.00
Incremental Delay, d2		5.7			2.9	5.2		1.8	1.0	0.6		13.7
Delay (s)		61.2			57.1	59.0		16.6	26.9	20.9		50.3
Level of Service		E			E	E		B	C	C		D
Approach Delay (s)		61.2			57.7				25.5			
Approach LOS		E			E				C			
Intersection Summary												
HCM 2000 Control Delay			34.1				HCM 2000 Level of Service				C	
HCM 2000 Volume to Capacity ratio			0.82									
Actuated Cycle Length (s)			150.0				Sum of lost time (s)				20.0	
Intersection Capacity Utilization			74.9%				ICU Level of Service				D	
Analysis Period (min)			15									
c Critical Lane Group												

HCM Signalized Intersection Capacity Analysis
 5: Rockville Pike & Twinbrook Pkwy

Alternative 1
 Timing Plan: PM Peak



Movement	SBT	SBR
Lane Configurations	↑↑↑	↗
Traffic Volume (vph)	1311	47
Future Volume (vph)	1311	47
Ideal Flow (vphpl)	1900	1900
Total Lost time (s)	5.5	
Lane Util. Factor	0.91	
Frt	0.99	
Flt Protected	1.00	
Satd. Flow (prot)	5107	
Flt Permitted	1.00	
Satd. Flow (perm)	5107	
Peak-hour factor, PHF	0.91	0.91
Adj. Flow (vph)	1441	52
RTOR Reduction (vph)	0	0
Lane Group Flow (vph)	1493	0
Heavy Vehicles (%)	1%	2%
Turn Type	NA	
Protected Phases	6	
Permitted Phases		
Actuated Green, G (s)	87.1	
Effective Green, g (s)	87.1	
Actuated g/C Ratio	0.58	
Clearance Time (s)	5.5	
Vehicle Extension (s)	0.2	
Lane Grp Cap (vph)	2965	
v/s Ratio Prot	0.29	
v/s Ratio Perm		
v/c Ratio	0.50	
Uniform Delay, d1	18.6	
Progression Factor	1.00	
Incremental Delay, d2	0.6	
Delay (s)	19.3	
Level of Service	B	
Approach Delay (s)	24.1	
Approach LOS	C	
Intersection Summary		

APPENDIX F COMMUNITY COMMENTS AND CITY RESPONSES

Rollins Avenue Complete Street Study
MwCOG Regional Roadway Safety Program
Public Comments and City Responses

City staff provided a presentation to the public on the Rollins Avenue Complete Street Study on May 7, 2026. Staff also directly reached out to apartment management companies and civic associations in the area, and residents who have provided comments on other transportation projects in the surrounding community.

All comments received are copied below and grouped by topic. A city response is provided after each comment group.

Bicycle Facilities

1. The approved Bikeway Master Plan proposes shared lanes for Rollins Avenue. Consistent with the plan, the study includes sharrows along Rollins Avenue. While sharrows can be helpful for directing bicycle traffic, they do not provide any substantial safety benefits. Designated and separated bicycle facilities are the best tools to improve bicyclist safety. Sharrows can supplement a bicycle network, but only if the roadway with sharrows has traffic moving at lower speeds.

RBAC recommends the city evaluate adding separated bicycle facilities along Rollins Avenue. If separated or traditional bicycle lanes are not possible, RBAC strongly supports adding traffic calming measures to supplement the proposed sharrows. This includes speed humps, curb extensions, and the pedestrian refuge shown in the study. RBAC recommends the sharrow markings be placed at intersections and every 200 feet and be supplemented by the “Bicycle May Use Full Lane” sign, consistent with MUTCD guidance.

2. Several residents also expressed concern that worsening congestion could negatively affect nearby businesses and shopping centers by discouraging customers from visiting the area. Feedback shared by the Montrose Civic association on this issue was overwhelmingly opposed, with no direct resident support expressed for the proposed bike lane concepts.

Response

The proposed improvements include shared lane markings, also known as “sharrows,” on Rollins Avenue. This is consistent with the approved Bikeway Master Plan. While bicycle lanes could be added by repurposing an on-street parking lane, much of the on-street parking is used by residents and visitors, or by those visiting Montrose Park, which does not have a dedicated parking lot. There is insufficient right-of-way space for separated bicycle lanes along Rollins Avenue. These can be considered as part of a future bicycle planning effort or if additional off-street parking is made available.

Bicycle lanes are not proposed as a quick-build or a long-term improvement in this study. Evaluating the impact of bicycle lanes on economic development is beyond the scope of this study, however, other peer-reviewed studies have shown a positive correlation between safe bicycling facilities and economic benefits along those streets.

Buffer

1. There is already a stripe buffering the parking from the travel lanes (at least on “our” side of Rollins).
2. There is currently a pavement marking line along Rollins Avenue from E. Jefferson Street to Evelyn Drive. This is helpful because it visually narrows the travel lane and more clearly indicates where motorists are permitted to park on-street. The study proposes a second parking lane striping or a wider marking. RBAC supports this recommendation. A wider buffer between the parking lane and the travel lane will further visually reduce the travel lane width, encourage motorists to travel more slowly. It will also help keep bicyclists out of the “door zone,” which is the roadway space where a bicyclist may be hit by a motorist opening their vehicle door after parking, without looking out for bicyclists.
3. Reducing roadway width or travel lanes could increase backups, and narrowing roadways may create additional congestion near already constrained intersections.

Response

Comments noted. Increasing the width of the buffer between the parking lane and travel lane will help visually narrow the travel lane to help ensure motorists travel at the posted speed limit or below. Painted buffers do not reduce the usable roadway space. Narrower travel lanes help reduce travel speed but do not impact capacity or create congestion. Vehicles are usually able to navigate intersections in the same manner prior to the lane narrowing.

Congestion

1. Traffic congestion in this area is already severe. Last month, I contacted the Montgomery County traffic engineering office regarding traffic on E. Jefferson Street. Each morning, it takes me approximately eight minutes to reach Old Georgetown Road from Rollins Avenue on a stretch of less than one mile, with seven traffic lights along the route. I am still working with the traffic engineer regarding signal timing on E. Jefferson.
2. In my view, a more effective way to reduce traffic on Rollins Avenue would be allowing westbound traffic from Twinbrook easier access to Route 355 (there is currently no left turn at the 355 intersection).
3. Proposed changes could worsen congestion and make access into and out of the neighborhood more difficult.
4. Residents generally emphasized that improvements should focus on improving traffic flow and neighborhood access rather than creating additional restrictions.
5. Preference for operational improvements, signal timing optimization, and enforcement before major infrastructure construction.
6. Residents from Montrose Civic Association repeatedly emphasized that traffic congestion is already severe along Rollins Avenue, E. Jefferson Street, Montrose Road, and surrounding intersections. Multiple residents described significant daily delays, particularly Rollins Avenue to E. Jefferson Street, E. Jefferson Street toward Old Georgetown Road, Rollins Avenue near Route 355, Rollins/Congressional Lane, and Rollins/Montrose.

Response

Congestion impacts for all proposed improvements were considered as part of the study. All improvements will maintain an adequate level of service at the E. Jefferson Street and Rollins Avenue and the Rockville Pike (MD 355) and Rollins Avenue intersections. This study also

evaluated operational changes at the Rockville Pike and Rollins Avenue intersection as well as the E. Jefferson Street and Rollins Avenue intersection.

Cost

1. The estimated project costs were viewed by several residents as excessive relative to perceived benefit.
2. Given the potential impacts, I believe these proposed construction changes should be evaluated very carefully to ensure they are truly effective and not simply an unnecessary use of public funds.
3. Concern that several proposed improvements may not justify their cost or potential disruption.

Response

The proposed near-term quick build improvements include flex post delineators, pavement markings, signs, and modifying the existing signal phasing. These are very low-cost improvements and can be incorporated into the city's existing budget for pedestrian and bicycle safety. The long-term improvements include concrete curbs, and sidewalk as well. These improvements are also low-cost improvements and can be incorporated into the existing Pedestrian and Bicycle Safety and Concrete Rehabilitation CIP projects.

Curb Extensions

1. Flex posts do not provide an attractive street appearance.
2. Concrete curb extensions are really wasting our precious street space and make turns more hard and dangerous.
3. Curb extensions would be another waste of time and money, it is and eye-sore and would achieve very little.
4. Curb extensions encourage motorists to navigate intersections at lower speeds, especially motorists turning at the intersection. Since right-hooks and le-turn angle crashes are common crash types between motorists and bicyclists, curb extensions can help reduce the likelihood of these crashes. However, curb extensions can also have a secondary impact on bicyclists, because they require a bicyclist to fully enter the travel lane when bicycling through an intersection. While bicyclists should be in the travel lane, many choose to ride on the outside of the travel lane or even at the edge of the parking lane to avoid motorists. Motorists may not expect a bicyclist to enter the travel lane when approaching a curb extension, creating a possible conflict. To address this, RBAC recommends that a sharrow marking be placed in the center of the travel lane, consistent with MUTCD guidance at the curb extension. Alternatively, RBAC recommends the city consider designing a curb extension for the long-term improvement that may be er accommodate bicyclists.

Response

Curb extensions are a valuable safety improvement for motorists and pedestrians, whether the curb extension is a permanent construction using concrete curb or a quick-build improvement using flex post delineators. Curb extensions have been used successfully in other locations in Rockville and across the region.

At an intersection, pedestrians waiting to cross can wait in the extension and are more visible to approaching motorists. Curb extensions also help ensure the line of sight for motorists is not blocked by parked vehicles while waiting to turn onto the street. Curb extensions reduce the

crossing distance for pedestrians, and reduces the roadway's total width, which encourages motorists to travel at the posted speed or below. Lastly, curb extensions require motorists to conduct turns at tighter angles, which requires a reduced travel speed. Turning at a lower speed not only helps motorists check for, and yield to, crossing pedestrians, but also reduces the severity of an impact should a crash occur.

The proposed quick-build improvements use flex post delineators to create curb extensions. These are a beneficial option because they can be implemented in a short amount of time, cost less than constructing concrete, and can help city staff evaluate their impact and make changes as necessary. Before the long-term solution is implemented, city staff will consider all received comments.

Cut Through Traffic and Access

1. Please, whatever you do, do not make any changes that would make our entrance to the neighborhood even more complicated. What I (and others) would appreciate is a plan that will allow us easier access/exit to/from the neighborhood, without allowing for cut through traffic.
2. During weekday afternoon rush hours, a high volume of cut-through traffic uses Rollins Avenue to bypass East Jefferson Street and reach Montrose Road.
3. A desire to reduce cut-through traffic while preserving resident access.
4. Proposed improvements could unintentionally worsen cut-through traffic patterns on nearby residential streets.
5. A recurring theme was that residents want solutions that improve neighborhood access while reducing cut-through traffic.
6. Cut-through traffic remains one of the neighborhood's primary concerns. Current traffic patterns push traffic through residential streets, create safety concerns for pedestrians and residents, and increase congestion on local neighborhood roads. Particularly along Evelyn Drive, Wilmart Street and traffic entering from Halpine Road, E. Jefferson Street, and Montrose Road.
7. Specific enforcement should consider cut-through traffic behavior.

Response

Cut through traffic occurs when a less direct route between desirable destinations is perceived by motorists as less congested and more accessible or faster moving. An effective approach to address cut-through traffic for residential streets such as Rollins Avenue, is to redesign the roadway to better reflect its residential surroundings. This includes reducing motorist travel speeds and providing improvements that better facilitate pedestrian and bicycle travel. These improvements also improve accessibility for people walking, rolling, and bicycling while maintaining motor vehicle access. Residents and visitors will still be able to drive to destinations along Rollins Avenue.

Roadway improvements designed to increase motor vehicle access will also increase travel speeds, which in turn will increase the number of motorists who perceive the route as a quicker and better option. Increasing motor vehicle access will increase cut through traffic.

E. Jefferson Street

1. 1. Strong opposition to proposed bike lane concepts on E. Jefferson Street.

2. Opposition to Bike Lanes and Shared Roadway Markings on E. Jefferson Street
3. This was one of the strongest areas of opposition in the responses received. Multiple residents strongly opposed proposed bike lanes or shared roadway markings on E. Jefferson Street, expressing concerns that E. Jefferson is already heavily congested and not well suited for additional bicycle infrastructure, encouraging bicycle traffic on an already busy roadway may increase conflicts between drivers, bicyclists, and pedestrians, additional lane reductions or roadway modifications could worsen congestion and lengthen traffic signal cycles, increased congestion may lead to more driver frustration and potentially more accidents, and existing bicycle infrastructure in the area appears underutilized.
4. It probably doesn't have any bearing on your recommendations, but I think it's worthwhile to point out in your map of existing and proposed bicycle facilities, East Jefferson starting at Rollins and going south is proposed to have separated bike lanes. The design has already been approved as part of the Federal Plaza redevelopment and will be implemented by the developer.
5. I also strongly oppose adding bike lanes or shared roadway markings on E. Jefferson Street. This is already a heavily traveled roadway. Encouraging additional bicycle traffic on such a busy corridor may increase congestion and create more conflicts between drivers, bicyclists, and pedestrians. Longer traffic light cycles and worsening congestion could increase frustration and ultimately lead to more accidents.

Response

While the E. Jefferson Street and Rollins Avenue intersection is included in this study, the segments of E. Jefferson Street north and south of Rollins Avenue is beyond the scope of this study. A prior study included E. Jefferson Street between Rollins Avenue and Congressional Lane and the city has plans to provide shared lane markings on E. Jefferson Street. Shared Lane Markings, also known as "Sharrows," do not reduce the number, or width of motor vehicle travel lanes nor impact traffic operations. Bicyclists are already permitted to travel on E. Jefferson Street in the motor vehicle travel lane. Shared lane markings are beneficial to multimodal roadway travel because they help direct bicyclists laterally to the best on the roadway and they indicate to motorists that the roadway may be used by people bicycling.

Economic Development

1. In addition, worsening traffic conditions could negatively impact local businesses by discouraging customers from nearby communities from visiting the shopping plazas. Many businesses in the area are already struggling. Several storefronts in Congressional Plaza have remained vacant for years. Continued economic decline could eventually lead to even higher taxes for residents. I believe any traffic improvement plan should take a broader and more comprehensive approach, carefully evaluating overall traffic patterns, business impact, safety, and long-term effectiveness rather than addressing isolated issues individually.
2. Economic impacts on nearby businesses from worsening congestion.

Response

The Rollins Avenue Complete Street Study focused on improving roadway safety, access, and mobility for people driving, walking, rolling, and bicycling along this corridor. Economic development is beyond the scope of the study. The existing businesses and vacancies reflect the existing roadway network and economic/financing variables such as customer base size

and proximity, customer base demographics, foot-traffic, competing businesses and developments in nearby areas, available finance, etc. It is not clear that the existing businesses or vacancies will improve if everything remains the same.

Enforcement

1. There should be increased enforcement for traffic violations, including existing turn restrictions, illegal left turns, and illegal right turns on red.

Response

Comments received. City staff has shared these concerns with the Rockville City Police Department and requested additional traffic enforcement along Rollins Avenue.

Parking

1. Vehicles parked on the west side of Rollins Avenue completely block the line of sight for drivers trying to make a left turn out of Marta Terrace. Removing these specific parking spaces will greatly improve visibility and prevent accidents.
2. Street parking should allow only cars or SUVs, not big trucks or utility trucks.
3. The Bethany House charges \$40/month to park, and this results in many people choosing to park on Rollins Avenue, including caretakers and visitors. The Rollins Park Community has parking costs rolled into rent.
4. There are no parking signs near the trees with the broken limbs on the section of Rollins Avenue near E. Jefferson Street, however cars aren't towed and enforcement should be better.
5. The south side of Rollins has residential permit parking. However, residents of these homes will often park on the north side of the street. This impacts the Bethany House employees, who do not have parking spots and often work overnight.
6. Unrestricted on-street parking should be permitted on both sides.
7. There are three pedestrian paths from the Rollins Park community that cross the sidewalk buffer and end at the curb. On-street vehicle parking often blocks these sidewalks. Pavement markings should be added here to prevent people from blocking these sidewalks.
8. Parking conditions on certain neighborhood streets.

Response

Curb extensions on the west end of Rollins Avenue at Martha Terrace/Evelyn Drive will help keep lines of sight clear for motorists turning onto Rollins Avenue, because motorists will not be able to park on-street at the intersection. Additionally, the proposed crosswalk at the Martha Terrace intersection closer to Montrose Park will also help keep the lines of sight clear because motorists are not permitted to park on-street within 20 feet of a marked crosswalk.

City Code Section 23-27 prevents certain types of trucks from parking on residential streets. If residents or visitors see certain trucks parked on residential streets, the Rockville City Police Department (RCPD) can be contacted and RCPD Parking Enforcement can address the violation. Other trucks, which are large, but meet regulations in the Maryland Transportation Title are permitted to park on public streets.

The price of parking at any private property along this corridor is beyond the scope of this project. On-street permitted parking is also beyond the scope of this project. Residents on the

south side of Rollins can petition to remove the designated residential permit parking. Designated permit parking may not be valuable if residents are parking on the north side of the street. Alternatively, residents on the north side of Rollins Avenue can petition to designate the north side of the street as a residential permit parking area consistent with City Code Section 23-44, however this would prevent non-residents from parking along this segment of Rollins Avenue.

Adding hatched pavement markings at the lead walks abutting the Rollins Park Community, would reduce the available on-street parking, which can be undesirable for community members. Additionally, adding no-parking area at a lead walk can often be interpreted by pedestrians as an official mid-block crossing, which can lead to other pedestrian safety challenges.

Pedestrian Refuge Median and Marked Crosswalks

1. I also question the need for the proposed median pedestrian refuge. I rarely see pedestrians crossing at that location, which is primarily vehicle traffic (I drive on this street almost everyday). Reducing two lanes to one lane near the Rollins/Montrose intersection could worsen congestion.
2. Adding crosswalks is warranted, as well as more enforcement.
3. RBAC supports the proposed crosswalk crossing Rollins Avenue at Martha Terrace near the southwest corner of Montrose Park as well as the mid-block crossing between E. Jefferson Street and Rockville Pike. Pedestrian refuge medians help pedestrians cross the street by encouraging motorists to travel at or below the posted speed limit and by giving pedestrians the opportunity to cross the street one traffic-direction at a time.
4. I support the mid-block crossing at the 7-11.
5. Support for additional crosswalks and pedestrian safety improvements in targeted locations. Frequently mentioned ideas including additional marked crosswalks, push-button activated pedestrian crossing signals, improved pedestrian crossings near the post office and residential entrances, and better pedestrian safety measures at high-use crossing locations.
6. Feedback from Montrose Civic Association on the median refuge concept leaned negative, though there was some support for pedestrian-focused improvements in select locations.
7. Reducing effective roadway width could worsen backups, congestion already extends toward Rockville Pike during peak periods, and additional narrowing may negatively affect traffic flow near major intersections.
8. Pedestrians regularly cross in this area, additional pedestrian safety measures are needed, particularly for seniors and residents walking from nearby housing, and some traffic delay may be acceptable if it improves pedestrian safety.

Response

The pedestrian refuge median will supplement the proposed midblock pedestrian crossing between the convenience store and the shopping center on Rollins Avenue between E. Jefferson Street and Rockville Pike. Staff observed pedestrians crossing this segment of Rollins Avenue during the field visit and has received comments from the Rockville Pedestrian Advocacy Committee during a May 2025 community walk that pedestrians frequently cross this portion of Rollins Avenue because of the commercial and residential land uses on either side.

For a midblock crossing, a pedestrian refuge is a safety feature that allows pedestrians to cross the roadway in two stages and observe traffic in one direction at a time. Additionally, the pedestrian refuge median will narrow the roadway travel lane widths which encourages motorists to drive at the posted speed limit of below.

Similar to other improvements, the quick-build improvement uses flex post delineators and pavement markings to designate the crosswalk and median area. City staff will consider comments prior to implementing the long-term concrete median.

Public Outreach Efforts

1. Unfortunately, I did not receive notice about the May 7 public meeting. Otherwise, I would have attended. In the future, I suggest placing a notification board with a QR code linking to the project website along the proposed road area so community members can be more easily informed and involved.
2. Frustration regarding limited outreach and insufficient early community engagement. Residents appreciate the City's willingness to gather feedback and request that future planning efforts continue to incorporate direct community input as the study progresses.
3. A widely shared concern among residents was that notification and outreach regarding the May 7 public meeting were insufficient. Multiple residents stated they did not receive notice of the meeting and would have attended if they had been informed. Several residents expressed frustration that major concepts appeared to have been developed before substantial neighborhood input was gathered. Residents encouraged the City to improve outreach and transparency moving forward, including, Earlier and broader notification to affected residents. More direct engagement with residents before concepts are finalized. Posting signage and QR codes along affected corridors linking to project information. Greater incorporation of resident priorities into transportation planning decisions.
4. Many residents emphasized that future redevelopment and rezoning projects in the surrounding area will significantly affect traffic conditions, and that transportation planning should take those future impacts into account holistically.

Response

Comments noted. City staff posted the presentation date on the city's online calendar and shared the meeting information with the Community Engagement office and during transportation related public meetings, similar to past studies. After fewer comments than expected were received, city staff directly reached out to apartment management companies, civic associations, and residents in the area who have participated in past projects. For future studies, city staff will follow some of these recommendations. City staff appreciates the comments received from organizations and residents in the community.

Rollins Avenue and E. Jefferson Street Intersection

1. When approaching Rollins Avenue from the south on E. Jefferson Street, there is a right turn only lane and a through/left turn lane. In many places in the county, the intersections will have a left turn only and through/right turn lane. Traffic will back up because people wanting to travel through the intersection are behind those wanting to turn left. Traffic light on E. Jefferson/Rollins.
2. Cars turning left onto Rollins Avenue hold up the through traffic in both directions.
3. The traffic lights at Rollins and E Jefferson, I pass through that intersection very often, as a driver and as a pedestrian. The main issue is the volume passing through there, and it will

just get worse (with all the future development). The suggestions might make the intersection safer, but it will also create heavier traffic. I don't see any advantage in adding more no turn in red, for that reason.

Response

The study proposes split signal phasing for the northbound and southbound travel movements. This would result in northbound and southbound vehicles traveling at different times of the signal cycle and reduce instances of through traffic being held up from left turning vehicles.

There is currently a no right turn on red restriction at the intersection of E. Jefferson Street and Rollins Avenue, during the peak travel periods. Staff has updated the recommendation to not extend the turning restriction to all-day.

Rollins Avenue and Rockville Pike (MD 355) Intersection

1. Several residents identified the Rollins Avenue and Route 355 intersection as one of the most problematic locations in the study area. Suggestions included improving turning movements, widening constrained portions of the roadway, adding or adjusting turn signal timing, improving intersection geometry, and improving signal timing optimization before pursuing major infrastructure changes.

Response

The Rollins Avenue and Rockville Pike (MD 355) intersection is owned by the Maryland Department of Transportation State Highway Administration (MDOT SHA) and operated by the Montgomery County Department of Transportation (MCDOT). The proposed improvements for this intersection include adding leading pedestrian intervals and prohibiting right turns on red. These will be shared with MDOT SHA and MCDOT once the study is complete. The public comments can be shared with them as well.

Sidewalks

1. Sidewalks are wide enough for pedestrians and wheelchairs. I walk everyday in the community and will report any issue if there is any.
2. I don't see any point in widening the sidewalks. Pedestrians, including people in wheelchairs and with strollers, move freely, I seriously doubt if someone ever not used the sidewalks, or felt uncomfortable, because it's 4 vs 5 ft. It can't be cheap to do and will be very disruptive for a while; I can recommend better things to do with the funds.
3. Sidewalks along Rollins Avenue already appear adequate for wheelchairs, strollers, pedestrian movement.
4. Will widening sidewalks from approximately four feet to five feet would provide meaningful public benefit relative to cost and disruption.
5. Opposition to several of the proposed physical traffic-calming or streetscape changes, particularly: sidewalk widening.
6. Many residents stated that sidewalks along Rollins Avenue already appear adequate for wheelchairs, strollers and pedestrian movement.
7. Sidewalks need to be at least five feet wide to meet Public Right of Way Accessibility Guidelines and ADA standards. While many bicyclists prefer traveling on the roadway, Rockville's City Code permits bicyclists to travel on the sidewalk, which is especially valuable for children and those just learning to ride. A wider sidewalk would allow those bicyclists to pass others on the sidewalk more safely. The Rollins Avenue traffic study

includes sidewalk widening as a long-term improvement. RBAC recommends the City widen these sidewalks sooner. Since the other proposed improvements do not require moving the curb or changing the right-of-way, sidewalk widening can be done on its own.

8. Several residents questioned whether widening sidewalks from approximately four feet to five feet would provide meaningful public benefit relative to cost and disruption.

Response

Sidewalks along Rollins Avenue are four-feet-wide and do not have passing spaces at intervals of 200 feet in places, which does not comply with Americans with Disabilities Act (ADA) standards or the federal Public Right of Way Guidelines (PROWAG). Sufficient passing spaces are required to ensure that two people using mobility devices are able to safely pass on a sidewalk should their paths cross. While individual residents may perceive the existing sidewalk widths as sufficient, they do not meet the accessibility standards. The Department of Public Works has an ongoing work program to reconstruct and retrofit all pedestrian facilities, including sidewalks, to meet ADA standards and PROWAG as the parallel roadway is resurfaced. Sidewalks along Rollins Avenue will be retrofitted with sufficient passing spaces to meet the ADA standards and PROWAG when the roadway is resurfaced.

Speeding and Speed Humps

1. Most of these vehicles come from Twinbrook Parkway and drive at fast, dangerous speeds. Please add a speed limit and multiple bumpers.
2. In my view, a more effective way to reduce traffic on Rollins Avenue would be keeping the speed camera on Rollins Avenue to control speeding without additional construction. This is a low cost and effective way.
3. Speed humps would likely create additional nighttime noise from vehicles braking and bumping over them, especially when traffic is lighter and cars travel faster. Traffic noise is already a concern along Rollins Avenue at night.
4. Speed bumps were suggested in the past for Rollins and Congressional Lane but residents didn't like the idea.
5. Other concerns included, speed humps may create nighttime noise from braking and acceleration, they may increase driver frustration, and they may not effectively address the root causes of congestion and cut-through traffic.
6. I am the Property Manager for Congressional Towers on Congressional Lane. I would like to express concerns about ongoing speeding issues in the area and the impact this is having on pedestrian safety. Excessive speeding is one of the main reasons pedestrians are at risk and why accidents continue to occur.
7. I would like to request increased traffic enforcement for the length of Rollins Ave and E Jefferson, including more speed watch activity and additional speed limit signage in areas where speeding is common. Greater visibility and enforcement would help slow traffic and improve safety for residents and pedestrians.
8. The study proposes speed humps as an add-on op on for both the near- and long-term improvements. RBAC supports the installation of speed humps along Rollins Avenue. Speed humps provide a vertical deflection in the road and encourage motorists to slow down. Lower motor vehicle speed increases the comfort for bicyclists and reduces the kinetic energy and impact severity should there be crashes.
9. School bus speeds on residential roads.
10. Maintaining the existing speed camera on Rollins Avenue.
11. Specific enforcement should include speeding on residential streets.

12. Some comments noted that existing speed humps in nearby areas have successfully slowed traffic, slower vehicle speeds improve pedestrian safety, especially for children, and additional traffic calming may help discourage cut-through traffic.
13. There should also be consideration of additional speed humps on other neighborhood streets experiencing speeding issues. Opposition to speed humps on Rollins Avenue outweighed support, although there was some support for targeted traffic calming in other parts of the neighborhood.

Response

The existing speed feedback sign on westbound Rollins Avenue between E. Jefferson Street and Martha Terrace will remain in place. City staff has also shared speeding related concerns raised by stakeholders with the Rockville City Police Department and requested additional enforcement. Speed humps are an effective improvement to reduce excessive speeding on residential roadways and unlike police enforcement, once they are constructed, speed humps can help encourage motorists to travel at the posted limit at all times of day. The city will consider these comments before any implementation.

Other

1. I also want to report a missing traffic sign on Congressional Lane in front of the Congressional Towers driveway. The “No Parking” sign with the directional arrow that was previously located in front of the first driveway was removed some time ago and has never been replaced. The cars parked along the curb are directly in front of the entrance blocking it. The missing sign has created confusion and should be restored.

Response

Thank you for the comment and notifying the city about this missing sign. While this is outside of the project extent, city staff has replaced this sign.

2. Unresolved roadway maintenance— a big pothole/dip near 618 Rollins Avenue that has already been reported to the city on March 5, 2026.
3. Road maintenance and unresolved potholes.

Response

Thank you for notifying us of the road maintenance needs on Rollins Avenue. This comment has been shared with the city’s Operations Maintenance and Construction Management Divisions, who will address the issue.

4. There are other community concerns that may deserve higher priority, including:
Ongoing dog waste issues on sidewalks and in common areas.

Response

Dog waste is beyond the scope of the Rollins Avenue Complete Street Study. If residents or visitors leave dog waste on public streets, the Code Enforcement Office can be contacted to address concerns and fine people for offences. Should dog waste be left on private sidewalks or in common areas, the management company or responsible organization can address the concern.

5. The cumulative impact of future redevelopment and rezoning.

Response

Zoning changes are beyond the scope of the Rollins Avenue Complete Streets Study. When development applications are submitted to the city, they are evaluated for traffic impacts and traffic mitigation improvements and transportation improvement fees are required of development applications consistent with the city's adequate public facilities ordinance, City Code Section 25.20. Congestion increases resulting from growth can be better addressed by investing in a more efficient transportation network that accommodates multimodal traffic than by seeking to expand an automobile-reliant transportation network. Expanding automobile capacity will result in more automobile-based trips, more cut-through traffic, and reduce quality of life for residents living on or near roadways that have been expanded.

6. Some residents requested a more comprehensive corridor-wide analysis rather than focusing on isolated segments of Rollins Avenue.

Response

The Rollins Avenue Complete Streets Study evaluated traffic conditions along the entire corridor of Rollins Avenue between its western terminus, west of Evelyn Drive, to its intersection with Rockville Pike.

7. Several residents emphasized that any pedestrian safety improvements should minimize unnecessary traffic delays.

Response

While impacts to traffic operations are taken into consideration, the City of Rockville has adopted and approved a Vision Zero Action Plan and transportation safety initiative. Eliminating fatalities and serious injuries caused by traffic crashes is prioritized above traffic delay. All improvements considered in this study maintained acceptable levels of services along the corridor.